OWNER'S MANUAL

MANUAL TROLLEY HOIST

MODEL SHB

1 Ton through 10 Ton Capacity

Code, Lot and Serial Number

⚠ WARNING

This equipment should not be installed, operated or maintained by any person who has not read and understood all the contents of this manual. Failure to read and comply with the contents of this manual can result in serious bodily injury or death, and/or property damage.

HARRINGTON
A KITO GROUP COMPANY

IMPORTANT INFORMATION ON HOW TO USE THIS MANUAL

This OWNER'S MANUAL is intended for use *in combination* with the "Owner's Manual for Manual Chain Hoist CB Series Model M3 1/2 Ton through 20 Ton Capacity". Refer to the Table of Contents below to determine the location(s) of information pertaining to your trolley hoist. References to the "Owner's Manual for Manual Chain Hoist CB Series Model M3 1/2 Ton through 20 Ton Capacity" will be designated by the use of the acronym "M3CBOM".

Table of Contents

Section	Page Number
1.0 Important Information and Warnings	4
1.1 Terms and Summary	
1.2 Warning Tags and Labels	
2.0 Technical Information.....	8
2.1 Specifications	
2.2 Dimensions	
2.3 Optional Equipment	
3.0 Preoperational Procedures	11
3.1 Trolley Adjustment	
3.2 Chain	
3.3 Installation of Trolley Hoist onto Beam	
3.4 Preoperational Checks and Trial Operation	
4.0 Operation	20
4.1 Introduction	
4.2 Shall's and Shall Not's for Operation	
4.3 Hoist Operation	
4.4 Trolley Operation	
5.0 Inspection	24
5.1 General	
5.2 Inspection Classification	
5.3 Frequent Inspection	
5.4 Periodic Inspection	

Section

Page Number

5.5	Occasionally Used Hoists	
5.6	Inspection Records	
5.7	Inspection Methods and Criteria	
6.0	Maintenance & Handling	32
6.1	Lubrication	
6.2	Storage	
6.3	Outdoor Installation	
6.4	Operational Environment	
7.0	Troubleshooting	34
8.0	Warranty	35
9.0	Parts List	36

1.0 Important Information and Warnings

1.1 Terms and Summary

This manual provides important information for personnel involved with the installation, operation and maintenance of this product. Although you may be familiar with this or similar equipment, it is strongly recommended that you read this manual before installing, operating, or maintaining the product.

Danger, Warning, Caution, and Notice

Throughout this manual there are steps and procedures that can present hazardous situations. The following signal words are used to identify the degree or level of hazard seriousness.

▲ DANGER Danger indicates an imminently hazardous situation which, if not avoided, **will** result in **death or serious injury**, and property damage.

▲ WARNING Warning indicates an imminently hazardous situation which, if not avoided, **could** result in **death or serious injury**, and property damage.

▲ CAUTION Caution indicates a potentially hazardous situation which, if not avoided, **may** result **minor or moderate injury** or property damage.

NOTICE Notice is used to notify people of installation, operation, or maintenance information which is important but not directly hazard-related.

▲ CAUTION

These general instructions deal with the normal installation, operation, and maintenance situations encountered with the equipment described herein. The instructions should not be interpreted to anticipate every possible contingency or to anticipate the final system, crane, or configuration that uses this equipment. For systems using the equipment covered by this manual, the supplier and owner of the system are responsible for the system's compliance with all applicable industry standards, and with all applicable federal, state, and local regulations/codes.

This manual includes instructions and parts information for a variety of hoist types. Therefore, all instructions and parts information may not apply to any one type or size of specific hoist. Disregard those portions of the instructions that do not apply.

Record your hoist's Code, Lot and Serial Number (see Section 9) on the front cover of this manual for identification and future reference to avoid referring to the wrong manual for information or instructions on installation, operation, inspection, maintenance, or parts.

Use only Harrington authorized replacement parts in the service and maintenance of this hoist.

WARNING

Equipment described herein is not designed for and **MUST NOT** be used for lifting, supporting, or transporting people, or for lifting or supporting loads over people.

Equipment described herein should not be used in conjunction with other equipment unless necessary and/or required safety devices applicable to the system, crane, or application are installed by the system designer, system manufacturer, crane manufacturer, installer, or user.

Modifications to upgrade, rerate, or otherwise alter this equipment shall be authorized only by the original equipment manufacturer.

Equipment described herein may be used in the design and manufacture of cranes or monorails. Additional equipment or devices may be required for the crane and monorail to comply with applicable crane design and safety standards. The crane designer, crane manufacturer, or user is responsible to furnish these additional items for compliance. Refer to ANSI/ASME B30.17, "Safety Standard for Top-Running Single Girder Cranes"; ANSI/ASME B30.2 "Safety Standard for Top-Running Double-Girder Cranes"; and ANSI/ASME B30.11 "Safety Standard for Underhung Cranes and Monorails".

If a below-the-hook lifting device or sling is used with a hoist, refer to ANSI/ASME B30.9, "Safety Standard for Slings" or ANSI/ASME B30.20, "Safety Standard for Below-the-Hook Lifting Devices".

Hoists used to handle hot molten material may require additional equipment or devices. Refer to ANSI Z241.2, "Safety Requirements for Melting and Pouring of Metals in the Metalcasting Industry".

Failure to read and comply with any one of the limitations noted herein can result in serious bodily injury or death, and/or property damage.

NOTICE

It is the responsibility of the owner/user to install, inspect, test, maintain, and operate a trolley or hoist in accordance with ANSI/ASME B30.16, "Safety Standard for Overhead Hoists", OSHA Regulations and ANSI/NFPA 70, "National Electric Code". If the trolley is installed as part of a total lifting system, such as an overhead crane or monorail, it is also the responsibility of the owner/user to comply with the applicable ANSI/ASME B30 volume that addresses that type of equipment.

It is the responsibility of the owner/user to have all personnel that will install, inspect, test, maintain, and operate a hoist read the contents of this manual and applicable portions of ANSI/ASME B30.16, "Overhead Hoists (Underhung)" and OSHA Regulations. If the trolley is installed as part of a total lifting system, such as an overhead crane, the applicable ANSI/ASME B30 volume that addresses that type of equipment must also be read by all personnel.

If the hoist owner/user requires additional information, or if any information in the manual is not clear, contact Harrington or the distributor of the hoist. Do not install, inspect, test, maintain, or operate this hoist unless this information is fully understood.

A regular schedule of inspection of the hoist in accordance with the requirements of ANSI/ASME B30.16 should be established and records maintained.

1.2 Warning Tags and Labels

The warning tag illustrated below in Figure 1-1 is supplied with each hoist shipped from the factory. If the tag is not attached to your trolley hoist's no-load side of the load chain, order a tag from your dealer and install it. Read and obey all warnings attached to this hoist. Tag is not shown actual size.

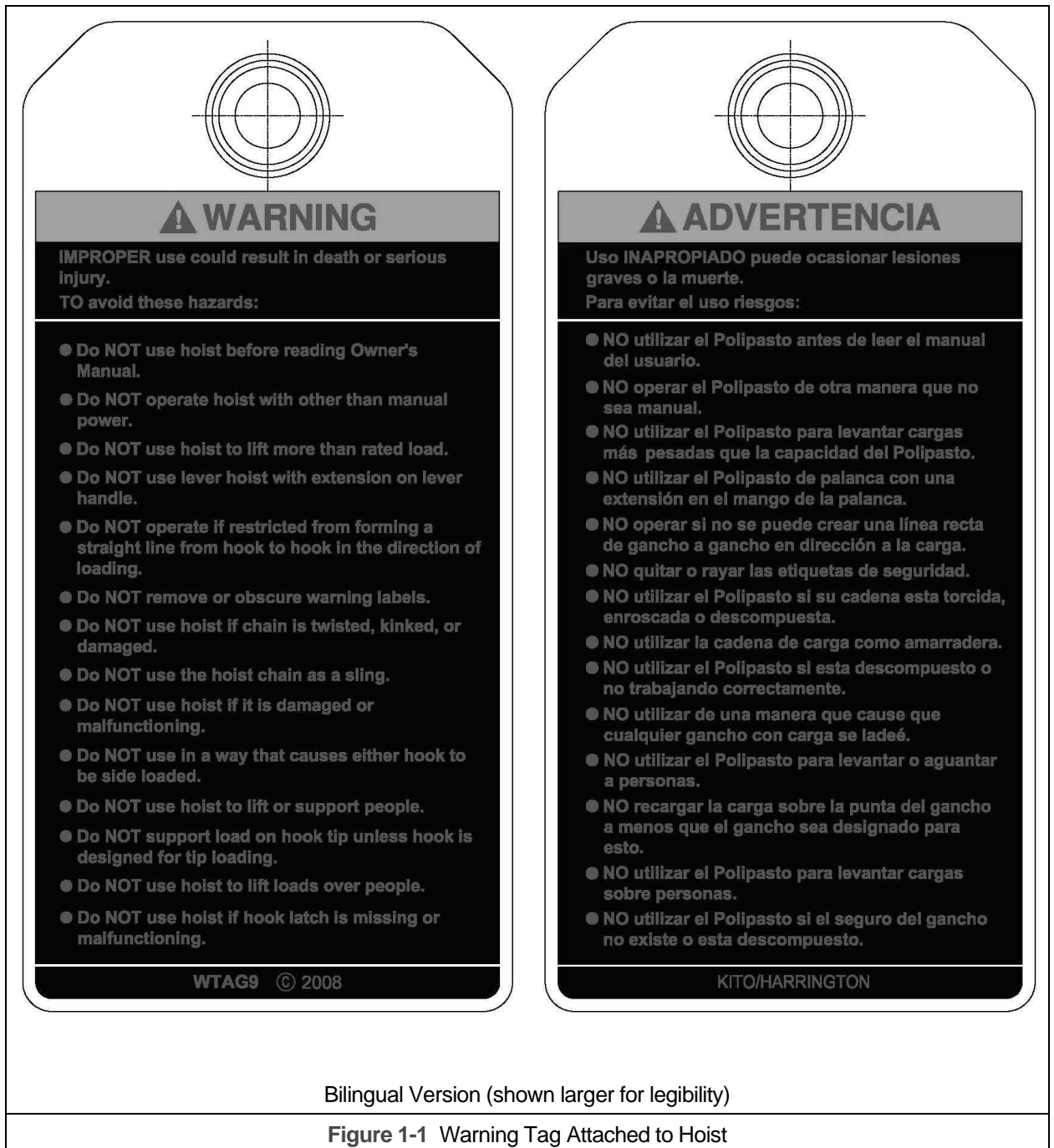

2.0 Technical Information

2.1 Specifications

2.1.1 Product Code

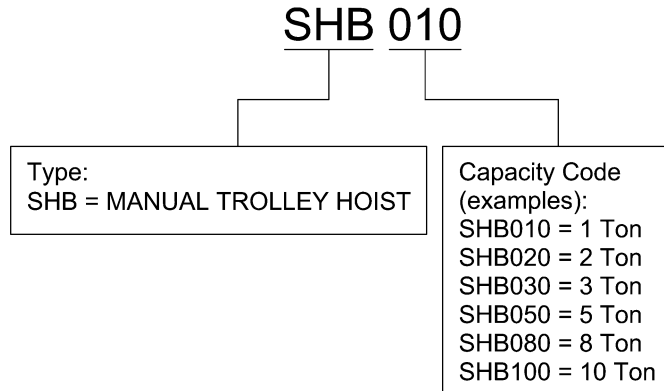

2.1.2 Operating Conditions and Environment

Temperature range: -4° to +140°F (-20° to +60°C)

Humidity: 100% or less (Not an Underwater Device)

Table 2-1 SHB Trolley Hoist Specifications

Cap. (Tons)	Product Code	Headroom C (in)	Std Lift ¹ (ft)	Pull to Lift Load (lbs)	Min. Radius for Curve ² (in)	Flange Width Adjustability B (in)		Load Chain Dia. (mm) x Chain Fall Lines	Net Weight ³ (lbs)	Shipping Weight Approx. (lbs)	Weight for Add'l. One ft of Lift (lbs)
						Standard	Option ⁴				
1	SHB010	4.5	20	64	N/A	2.28 to 6.42	6.43 to 12.00	5.0 x 2	166	176	2.0
2	SHB020	5.7		58		3.23 to 8.03	8.04 to 12.00	7.1 x 2	271	281	2.8
3	SHB030	6.5		74		3.94 to 8.03		8.0 x 2	385	395	3.1
5	SHB050	7.7		90			9.0 x 2	655	665	3.7	
8	SHB080	10.0		74		5.50 to 8.66	8.67 to 12.00	9.0 x 4	858	868	6.1
10	SHB100			96							

¹Special lengths of load and hand chain available upon request.

²Due to wheelbase length, the SHB cannot negotiate a curve.

³Weights are for standard flange width.

⁴See Parts List for optional flange kits.

2.2 Dimensions

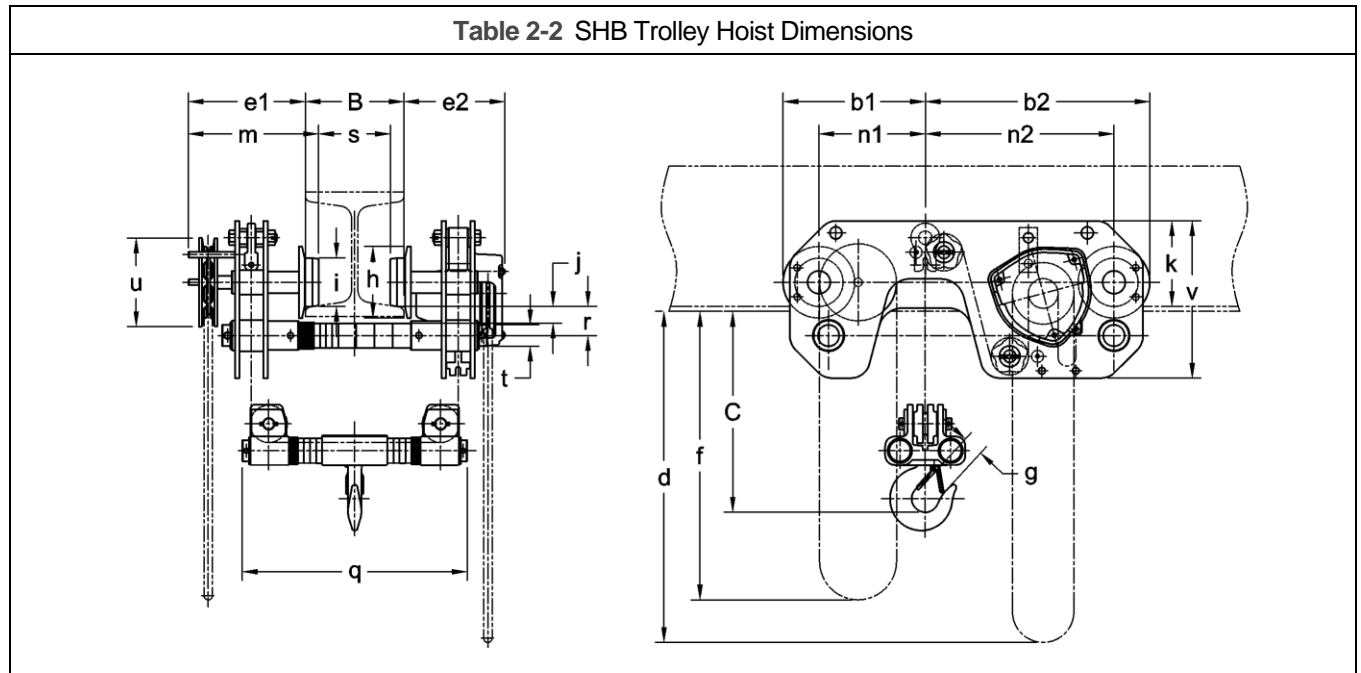

Cap. (Tons)	Product Code	b1 (in)	b2 (in)	d (ft)	e1 (in)	e2 (in)	f (ft)	g (in)	h (in)	i (in)	j (in)	k (in)	m (in)	n1 (in)	n2 (in)	q (in)	r (in)	s (in)	t (in)	u (in)	v (in)
1	SHB010	8.0	13.5	19.3	7.9	7.0	19.3	1.1	4.17	2.80	1.0	4.5	8.7	5.9	11.4	14.6	1.8	B-1.6	1.22	6.02	9.6
2	SHB020	9.6	15.7		8.9	7.6		1.4	5.00	3.35	1.2	6.6	9.9	7.1	13.2	17.3	2.1	B-2.0	1.42		11.4
3	SHB030	11.6	18.3		9.5	8.1		1.7	5.83	3.94	1.3	7.0	10.6	8.7	15.4	18.3	2.4	B-2.2	1.73	7.20	12.8
5	SHB050	13.8	21.3		10.5	8.8		1.8	6.65	4.65	1.4	8.8	11.9	10.4	17.9	19.5	2.8	B-2.9	2.17		15.4
8	SHB080	15.5	23.1		11.4	8.5		2.4	7.29	6.10	1.3	10.5	13.2	11.8	19.4	19.6	3.3	B-3.5	2.76	8.43	16.5
10	SHB100																				

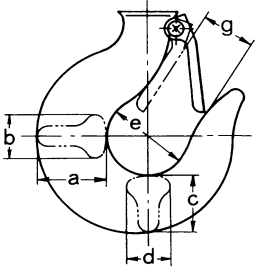
Table 2-3 Bottom Hook Dimension*							
				B = Bottom Hook Units = inch (mm)			
Cap. (Tons)	Product Code	a	b	c	d	e	g
1	SHB010	1.0 (26)	0.6 (16)	0.9 (22)	0.6 (16)	1.7 (43)	1.1 (29)
2	SHB020	1.4 (36)	0.9 (22)	1.2 (30)	0.9 (22)	2.0 (50)	1.4 (36)
3	SHB030	1.8 (45)	1.1 (27)	1.5 (38)	1.1 (27)	2.2 (56)	1.7 (43)
5	SHB050	2.2 (56)	1.4 (35)	1.9 (48)	1.4 (35)	2.5 (63)	1.8 (47)
8	SHB080	3.3 (83)	2.2 (55)	2.9 (73)	1.9 (48)	3.3 (85)	2.4 (62)
10	SHB100	3.3 (83)	2.2 (55)	2.9 (73)	1.9 (48)	3.3 (85)	2.4 (62)

*Refer to Section 5.7 for inspection dimensions and limits.

2.3 Optional Equipment

2.3.1 Optional Chain Containers

- Chain containers are sized based on the capacity and lift of the hoist. The containers are constructed from vinyl coated canvas or steel. See Parts List for chain container kits.

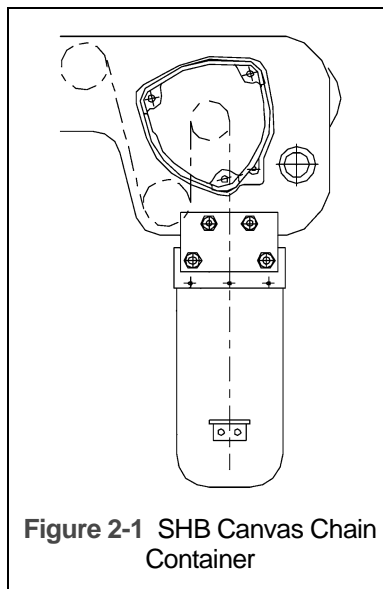

3.0 Preoperational Procedures

3.1 Trolley Adjustment

- 3.1.1 **NOTICE** Before use, the trolley can be adjusted in increments of 1/8" by simply inserting or removing adjusting spacers to fit a variety of beam flanges. Adjustments must be made to the Upper Suspension Shaft and to the Lower Suspension Shaft.
- 3.1.2 To adjust the Upper Suspension Shaft reference Figure 3-1 and Table 3-2. Proceed with the following instructions:
1. Remove all of the suspension shaft bolts.
 2. Shift both the handwheel (Side Plate G) and manual chain hoist (Side Plate S) collars to the appropriate hole positions according to the selected beam width. Reinsert the appropriate number of inner spacers for the desired flange width as indicated in Table 3-2.
 3. "Inner" means between the side plates and "outer" means outside of the side plates.
 4. For designations such as "X + Y", "X" is on the trolley hand wheel side and "Y" is on the hoist side.

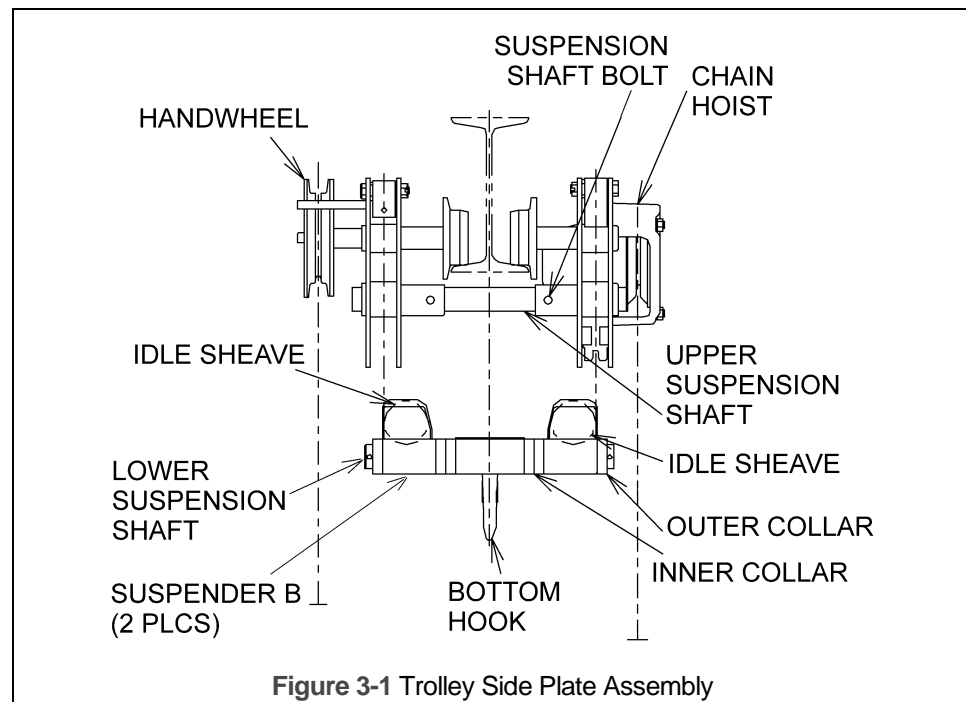

- 3.1.3 To adjust the Lower Suspension Shaft reference Figure 3-1 and Table 3-3. Proceed with the following instructions:
1. Remove all of the lower suspension shaft pins.
 2. To make the adjustment, replace the inner and outer collars as shown in Figure 3-1.
 3. Table 3-3 provides the spacer arrangement information. Take note of the number of spacers on the "inner" side.
 4. "Inner" means between the suspender "B's", and "outer" means outside of the suspender "B's".
 5. For designations such as "X + Y", "X" is on the trolley hand wheel side and "Y" is on the hoist (CB) side.

Table 3-2 Number of Adjusting Spacers - Upper Suspension Shaft

Beam Flange Width		(in)	2 5/16	2 1/2	2 5/8	2 7/8	3	3 1/4	3 9/16	3 7/8	3 15/16	4	4 3/16	4 7/16	4 1 1/16	4 1 5/16	5	5 3/16	5 5/16	5 3/8	5 1/2	5 5/8	5 7/8	6	6 3/16	6 5/16	6 7/16	
Cap (Ton)	Spacer Type	(mm)	58	64	66	73	76	82	91	98	100	102	106	113	119	125	127	131	135	137	140	143	150	153	157	160	163	
1	Thin	Inner	1	3	0	2	3	1	0	2	2	3	0	3	1	2	3	0	2	2	3	0	2	3	1	2	3	
		Outer	1+3	1+1	1+4	1+2	1+1	1+3	1+4	1+2	1+2	1+1	1+4	1+1	1+3	1+2	1+1	1+4	1+2	1+2	1+1	1+4	1+2	0+2	2+2	1+2	1+1	
	Thick	Inner	1	1	2	2	2	3	4	4	4	4	1	1	2	2	2	3	3	3	3	4	4	4	4	5	5	5
		Outer	1+3	1+3	1+2	1+2	1+2	1+1	1+0	1+0	1+0	1+0	1+3	1+3	1+2	1+2	1+2	1+1	1+1	1+1	1+1	1+1	1+0	1+0	1+0	0+0	0+0	0+0
	Fixing	Inner	1	1	1	1	1	1	1	1	1	1	2	2	2	2	2	2	2	2	2	2	2	2	2	2	2	2
		Outer	0+1	0+1	0+1	0+1	0+1	0+1	0+1	0+1	0+1	0+1	0+0	0+0	0+0	0+0	0+0	0+0	0+0	0+0	0+0	0+0	0+0	0+0	0+0	0+0	0+0	0+0
C	Inner	2	2	2	2	2	2	2	2	2	2	2	2	2	2	2	2	2	2	2	2	2	2	2	2	2	2	
	Outer																											
2	Thin	Inner						5	3	6	6	3	4	6	4	6	3	4	5	6	3	4	6	3	4	5	6	
		Outer						3+2	3+4	3+1	3+1	3+4	3+3	3+1	3+3	3+1	3+4	3+3	3+2	3+1	3+4	3+3	3+1	3+4	3+3	3+1	3+1	
	Thick	Inner						1	2	2	2	0	0	0	1	1	2	2	2	2	0	0	0	1	1	1	1	
		Outer						1+2	1+1	1+1	1+1	1+3	1+3	1+3	1+2	1+2	1+1	1+1	1+1	1+1	1+1	1+3	1+3	1+3	1+2	1+2	1+2	1+2
	Fixing	Inner						2	2	2	2	3	3	3	3	3	3	3	3	3	3	4	4	4	4	4	4	4
		Outer						0+2	0+2	0+2	0+2	0+1	0+1	0+1	0+1	0+1	0+1	0+1	0+1	0+1	0+1	0+0	0+0	0+0	0+0	0+0	0+0	0+0
3	Thin	Inner						6	4	6	7	4	5	7	5	7	4	5	6	7	4	5	7	4	5	6	7	
		Outer						3+2	3+4	3+2	3+1	3+4	3+3	3+1	3+3	3+1	3+4	3+3	3+2	3+1	3+4	3+3	3+1	3+4	3+3	3+1	3+1	
	Thick	Inner						1	2	2	2	3	3	3	1	1	2	2	2	2	3	3	3	1	1	1	1	
		Outer						1+2	1+1	1+1	1+1	1+0	1+0	1+0	1+2	1+2	1+1	1+1	1+1	1+1	1+1	1+0	1+0	1+0	1+2	1+2	1+2	1+2
	Fixing	Inner						2	2	2	2	2	2	2	3	3	3	3	3	3	3	3	3	3	4	4	4	4
		Outer						0+2	0+2	0+2	0+2	0+2	0+2	0+2	0+1	0+1	0+1	0+1	0+1	0+1	0+1	0+1	0+1	0+1	0+0	0+0	0+0	0+0
5	Thin	Inner									2	2	3	2	3	5	2	3	5	5	2	3	5	2	4	5	2	
		Outer									3+4	3+4	3+3	3+4	3+3	3+1	3+4	3+3	3+1	3+1	3+4	3+3	3+1	3+4	3+2	3+1	3+4	
	Thick	Inner									10	10	10	11	11	11	12	12	12	12	13	13	13	14	14	14	15	
		Outer									1+6	1+6	1+6	1+5	1+5	1+5	1+4	1+4	1+4	1+4	1+3	1+3	1+3	1+2	1+2	1+2	1+1	
	Fixing	Inner									0	0	0	0	0	0	0	0	0	0	0	0	0	0	0	0	0	
		Outer									0+0	0+0	0+0	0+0	0+0	0+0	0+0	0+0	0+0	0+0	0+0	0+0	0+0	0+0	0+0	0+0	0+0	
8 & 10	Thin	Inner																			3	4	3	4	5	6	3	
		Outer																			4+4	4+3	4+4	4+3	4+2	4+1	4+4	
	Thick	Inner																			2	2	3	3	3	3	4	
		Outer																			1+4	1+4	1+3	1+3	1+3	1+3	1+2	
	Fixing	Inner																			3	3	3	3	3	3	3	
		Outer																			0+0	0+0	0+0	0+0	0+0	0+0	0+0	

Table 3-2 Number of Adjusting Spacers - Upper Suspension Shaft (Continued)

Beam Flange Width		(in)	6 ¹¹ / ₁₆	6 ⁷ / ₈	7	7 ¹ / ₁₆	7 ¹ / ₄	7 ⁷ / ₈	8	8 ⁷ / ₈	8 ¹¹ / ₁₆	9	9 ¹ / ₈	9 ⁷ / ₈	10	10 ¹ / ₈	10 ¹ / ₄	10 ³ / ₈	10 ¹ / ₂	11	11 ¹ / ₈	11 ¹ / ₄	11 ³ / ₈	11 ⁵ / ₈	11 ³ / ₄	11 ⁷ / ₈	12
Cap (Ton)	Spacer Type	(mm)	170	175	178	180	184	200	203	215	220	229	232	250	254	257	260	264	267	279	283	286	289	295	298	302	305
1	Thin	Inner	9	7	8	9	6	7	8	8	9	8	9	7	8	9	6	8	8	8	3	7	8	9	6	8	9
		Outer	1+1	1+3	1+2	1+1	1+4	1+3	1+2	1+2	1+1	1+2	1+1	1+3	1+2	1+1	1+4	1+2	1+2	1+2	1+1	1+3	1+2	1+1	4+1	2+1	1+1
	Thick	Inner	0	1	1	1	2	3	3	0	0	1	1	3	3	3	4	4	4	5	5	6	6	6	7	7	7
		Outer	1+6	1+5	1+5	1+5	1+4	1+3	1+3	1+6	1+6	1+5	1+5	1+3	1+3	1+3	1+2	1+2	1+2	1+1	1+1	1+0	1+0	1+0	0+0	0+0	0+0
	Fixing	Inner	3	3	3	3	3	3	3	4	4	4	4	4	4	4	4	4	4	4	4	4	4	4	4	4	4
		Outer	0+1	0+1	0+1	0+1	0+1	0+1	0+1	0+0	0+0	0+0	0+0	0+0	0+0	0+0	0+0	0+0	0+0	0+0	0+0	0+0	0+0	0+0	0+0	0+0	0+0
C	Inner	2	2	2	2	2	2	2	2	2	2	2	2	2	2	2	2	2	2	2	2	2	2	2	2	2	
2	Thin	Inner	5	6	3	4	5	6	7	3	4	3	4	6	3	4	5	3	4	3	5	6	7	8	5	7	8
		Outer	3+2	3+1	3+4	3+3	3+2	3+1	2+1	3+4	3+3	3+4	3+3	3+1	3+4	3+3	3+2	3+4	3+3	3+4	3+2	3+1	2+1	1+1	4+1	2+1	1+1
	Thick	Inner	2	2	3	3	3	4	4	0	0	1	1	2	3	3	3	4	4	5	5	5	5	5	6	6	6
		Outer	1+1	1+1	1+0	1+0	1+0	0+0	0+0	1+5	1+5	1+4	1+4	1+3	1+2	1+2	1+2	1+1	1+1	1+0	1+0	1+0	1+0	1+0	0+0	0+0	0+0
	Fixing	Inner	4	4	4	4	4	4	4	6	6	6	6	6	6	6	6	6	6	6	6	6	6	6	6	6	6
		Outer	0+0	0+0	0+0	0+0	0+0	0+0	0+0	0+0	0+0	0+0	0+0	0+0	0+0	0+0	0+0	0+0	0+0	0+0	0+0	0+0	0+0	0+0	0+0	0+0	0+0
3	Thin	Inner	5	7	4	5	6	7	8	4	5	4	5	7	4	5	6	4	5	4	6	7	8	9	6	8	9
		Outer	3+3	3+1	3+4	3+3	3+2	3+1	2+1	3+4	3+3	3+4	3+3	3+1	3+4	3+3	3+2	3+4	3+3	3+4	3+2	3+1	2+1	1+1	4+1	2+1	1+1
	Thick	Inner	2	2	3	3	3	4	4	0	0	1	1	2	3	3	3	6	4	5	5	5	5	5	6	6	6
		Outer	1+1	1+1	1+0	1+0	1+0	0+0	0+0	1+5	1+5	1+4	1+4	1+3	1+2	1+2	1+2	1+1	1+1	1+0	1+0	1+0	1+0	1+0	0+0	0+0	0+0
	Fixing	Inner	4	4	4	4	4	4	4	6	6	6	6	6	6	6	6	4	6	6	6	6	6	6	6	6	6
		Outer	0+0	0+0	0+0	0+0	0+0	0+0	0+0	0+0	0+0	0+0	0+0	0+0	0+0	0+0	0+0	0+0	0+0	0+0	0+0	0+0	0+0	0+0	0+0	0+0	0+0
5	Thin	Inner	4	5	2	3	4	5	6	2	3	2	3	5	2	3	4	2	3	2	4	5	6	7	4	6	7
		Outer	3+2	3+1	3+4	3+3	3+2	3+1	2+1	3+4	3+3	3+4	3+3	3+1	3+4	3+3	3+2	3+4	3+3	3+4	3+2	3+1	2+1	2+1	4+1	2+1	1+1
	Thick	Inner	15	15	16	16	16	17	17	19	19	20	20	21	22	22	22	23	23	24	24	24	24	24	25	25	25
		Outer	1+1	1+1	1+0	1+0	1+0	0+0	0+0	1+5	1+5	1+4	1+4	1+3	1+2	1+2	1+2	1+1	1+1	1+0	1+0	1+0	1+0	1+0	0+0	0+0	0+0
	Fixing	Inner	0	0	0	0	0	0	0	0	0	0	0	0	0	0	0	0	0	0	0	0	0	0	0	0	0
		Outer	0+0	0+0	0+0	0+0	0+0	0+0	0+0	0+0	0+0	0+0	0+0	0+0	0+0	0+0	0+0	0+0	0+0	0+0	0+0	0+0	0+0	0+0	0+0	0+0	0+0
8 & 10	Thin	Inner	5	3	4	4	5	7	8	7	9	3	4	1	3	4	1	2	3	3	4	5	6	4	5	6	7
		Outer	4+2	4+4	4+3	4+3	4+2	3+1	2+1	3+1	1+1	4+2	4+1	4+4	4+2	4+1	4+4	4+3	4+2	4+2	4+1	3+1	2+1	4+1	3+1	2+1	1+1
	Thick	Inner	4	5	5	5	5	6	6	7	7	0	0	2	2	2	3	3	3	4	4	4	4	5	5	5	5
		Outer	1+2	1+1	1+1	1+1	1+1	1+0	1+0	0+0	0+0	1+4	1+4	1+2	1+2	1+2	1+1	1+1	1+1	1+0	1+0	1+0	1+0	0+0	0+0	0+0	0+0
	Fixing	Inner	3	3	3	3	3	3	3	3	3	6	6	6	6	6	6	6	6	6	6	6	6	6	6	6	6
		Outer	0+0	0+0	0+0	0+0	0+0	0+0	0+0	0+0	0+0	0+0	0+0	0+0	0+0	0+0	0+0	0+0	0+0	0+0	0+0	0+0	0+0	0+0	0+0	0+0	0+0

Table 3-3 Number of Adjusting Spacers – Lower Suspension Shaft

Beam Flange Width		(in)	2 5/16	2 1/2	2 5/8	2 7/8	3	3 1/4	3 9/16	3 7/8	3 15/16	4	4 3/16	4 7/16	4 1 1/16	4 1 5/16	5	5 3/16	5 5/16	5 3/8	5 1/2	5 5/8	5 7/8	6	6 3/16	6 5/16	6 7/16	
Cap (Ton)	Spacer Type	(mm)	58	64	66	73	76	82	91	98	100	102	106	113	119	125	127	131	135	137	140	143	150	153	157	160	163	
1	Thin	Inner	1+2	2+3	3+3	0+4	0+1	1+2	3+3	0+4	0+4	0+1	1+1	2+3	3+4	0+4	0+1	1+1	2+2	2+2	2+3	3+3	4+4	4+5	5+6	6+6	6+7	
		Outer	6+6	6+4	6+3	6+5	6+8	6+6	4+5	7+4	7+4	7+7	6+7	5+5	4+4	7+4	7+7	6+7	5+6	5+6	5+5	4+5	3+4	3+3	2+2	1+2	1+1	
	Thick	Inner	0+0	0+0	0+0	1+0	1+1	1+1	1+1	2+1	2+1	2+2	2+2	2+2	2+2	3+2	3+3	3+3	3+3	3+3	3+3	3+3	3+3	3+3	3+3	3+3	3+3	3+3
		Outer	2+4	2+4	2+4	2+3	2+2	2+2	2+2	1+2	1+2	1+1	1+1	1+1	1+1	0+1	0+0	0+0	0+0	0+0	0+0	0+0	0+0	0+0	0+0	0+0	0+0	0+0
	Fixing	Inner	0+0	0+0	0+0	0+0	0+0	0+0	0+0	0+0	0+0	0+0	0+0	0+0	0+0	0+0	0+0	0+0	0+0	0+0	0+0	0+0	0+0	0+0	0+0	0+0	0+0	0+0
		Outer	0+0	0+0	0+0	0+0	0+0	0+0	0+0	0+0	0+0	0+0	0+0	0+0	0+0	0+0	0+0	0+0	0+0	0+0	0+0	0+0	0+0	0+0	0+0	0+0	0+0	0+0
2	Thin	Inner						2+1	3+2	4+4	4+4	5+4	5+5	2+2	3+3	4+4	5+4	5+5	2+5	2+2	3+2	3+3	4+4	5+4	5+5	2+5	2+2	
		Outer						4+5	3+4	2+2	2+2	1+2	1+1	4+4	3+3	2+2	1+2	1+1	4+1	4+4	3+4	3+3	2+2	1+2	1+1	4+1	4+4	
	Thick	Inner						1+1	1+1	1+1	1+1	1+1	1+1	2+2	2+2	2+2	2+2	2+2	3+2	3+3	3+3	3+3	3+3	3+3	3+3	3+3	4+3	4+4
		Outer						4+4	4+4	4+4	4+4	4+4	4+4	3+3	3+3	3+3	3+3	3+3	2+3	2+2	2+2	2+2	2+2	2+2	2+2	2+2	1+2	1+1
	Fixing	Inner						0+0	0+0	0+0	0+0	0+0	0+0	0+0	0+0	0+0	0+0	0+0	0+0	0+0	0+0	0+0	0+0	0+0	0+0	0+0	0+0	0+0
		Outer						0+0	0+0	0+0	0+0	0+0	0+0	0+0	0+0	0+0	0+0	0+0	0+0	0+0	0+0	0+0	0+0	0+0	0+0	0+0	0+0	0+0
3	Thin	Inner						2+1	3+2	4+3	4+0	5+0	5+1	2+2	3+3	4+0	5+0	5+1	2+1	2+2	3+2	3+3	4+0	5+0	5+1	2+1	2+2	
		Outer						4+5	3+4	2+3	2+6	1+6	1+5	4+4	3+3	2+6	1+6	1+5	4+5	4+4	3+4	3+3	2+6	1+6	1+5	4+5	4+4	
	Thick	Inner						0+0	0+0	0+0	0+1	0+1	0+1	1+1	1+1	1+2	1+2	1+2	2+2	2+2	2+2	2+2	2+3	2+3	2+3	3+3	3+3	
		Outer						4+4	4+4	4+4	4+3	4+3	4+3	3+3	3+3	3+2	3+2	3+2	2+2	2+2	2+2	2+2	2+1	2+1	2+1	1+1	1+1	
	Fixing	Inner						0+0	0+0	0+0	0+0	0+0	0+0	0+0	0+0	0+0	0+0	0+0	0+0	0+0	0+0	0+0	0+0	0+0	0+0	0+0	0+0	0+0
		Outer						0+0	0+0	0+0	0+0	0+0	0+0	0+0	0+0	0+0	0+0	0+0	0+0	0+0	0+0	0+0	0+0	0+0	0+0	0+0	0+0	0+0
5	Thin	Inner									0+0	0+0	0+0	0+0	0+0	0+0	0+0	0+1	1+2	1+2	2+2	2+3	3+4	4+4	1+5	1+6	2+6	
		Outer									5+6	5+6	5+6	5+6	5+6	5+6	5+6	5+5	4+4	4+4	3+4	3+3	2+2	1+2	4+1	4+0	3+0	
	Thick	Inner										0+0	0+0	0+0	0+0	0+0	0+0	0+0	0+0	0+0	0+0	0+0	0+0	0+0	1+0	1+0	1+0	
		Outer										2+2	2+2	2+2	2+2	2+2	2+2	2+2	2+2	2+2	2+2	2+2	2+2	2+2	2+2	1+2	1+2	1+2
	Fixing	Inner										0+0	0+0	0+0	0+0	0+0	0+0	0+0	0+0	0+0	0+0	0+0	0+0	0+0	0+0	0+0	0+0	0+0
		Outer										0+0	0+0	0+0	0+0	0+0	0+0	0+0	0+0	0+0	0+0	0+0	0+0	0+0	0+0	0+0	0+0	0+0
8 & 10	Thin	Inner																				3+2	3+2	4+4	5+4	5+5	6+5	6+6
		Outer																					5+6	5+6	4+4	3+4	3+3	2+3
	Thick	Inner																					0+0	0+0	0+0	0+0	0+0	0+0
		Outer																						2+2	2+2	2+2	2+2	2+2
	Fixing	Inner																						0+0	0+0	0+0	0+0	0+0
		Outer																							0+0	0+0	0+0	0+0

3.2 Chain

- 3.2.1 **⚠️WARNING** Verify that the load chain is not twisted or tangled prior to operating the hoist. Make sure the bottom hook is not capsized. See Figure 3-2 and Figure 3-3. Correct all chain irregularities before conducting the first trolley hoist operation.

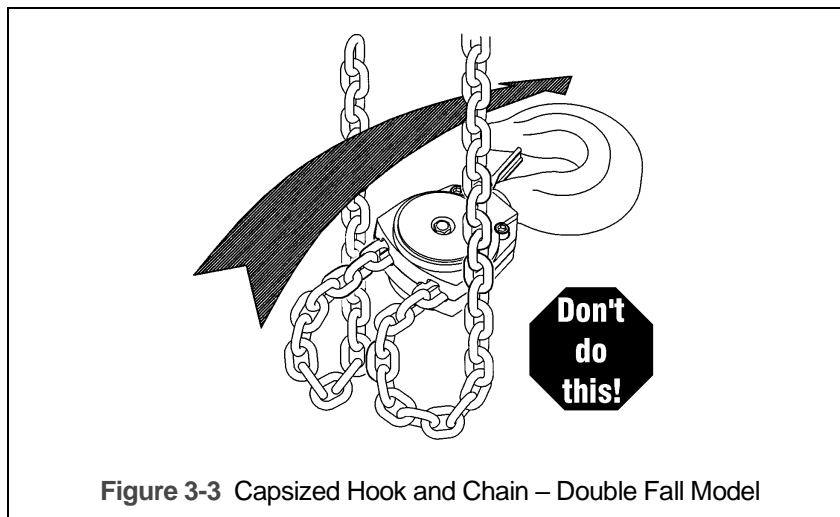
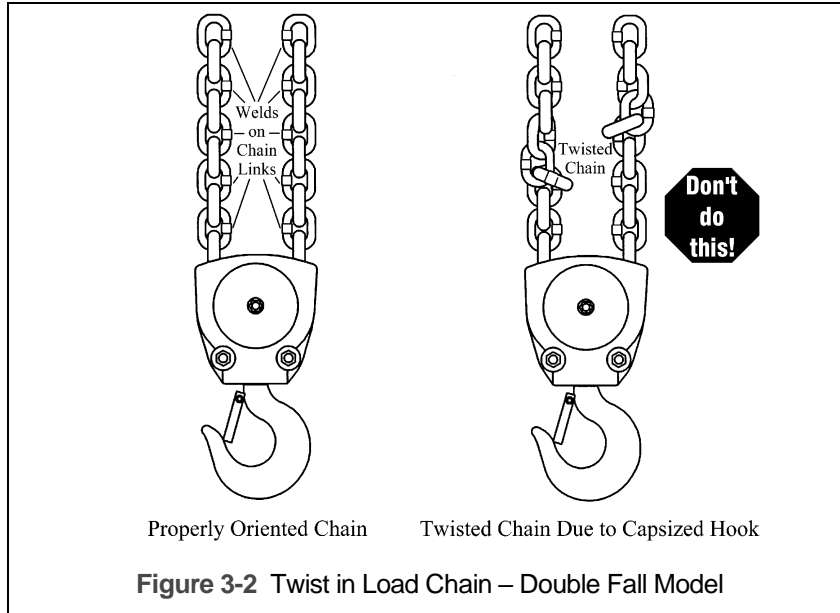

- 3.2.2 **Optional Canvas Chain Container** - When the optional canvas chain container is selected, fully unfold and install it on the hoist body as shown in Figure 3-4. The free end of the chain is not attached to the hoist body and the chain stopper is installed on the third link from the free end. To place the chain into the chain container, feed the free end of the chain into the container. Take care to avoid twisting or tangling the chain. NEVER put all the chain into the container at once. Lumped or twisted chain may stop the hoist during lifting and lowering.

- 3.2.3 **CAUTION** Each chain container indicates the maximum length of the load chain that can be stored in the container. The amount of chain the container must hold is equal to the lift on the hoist. DO NOT use a chain container with a storage capacity less than the lift length on the hoist.

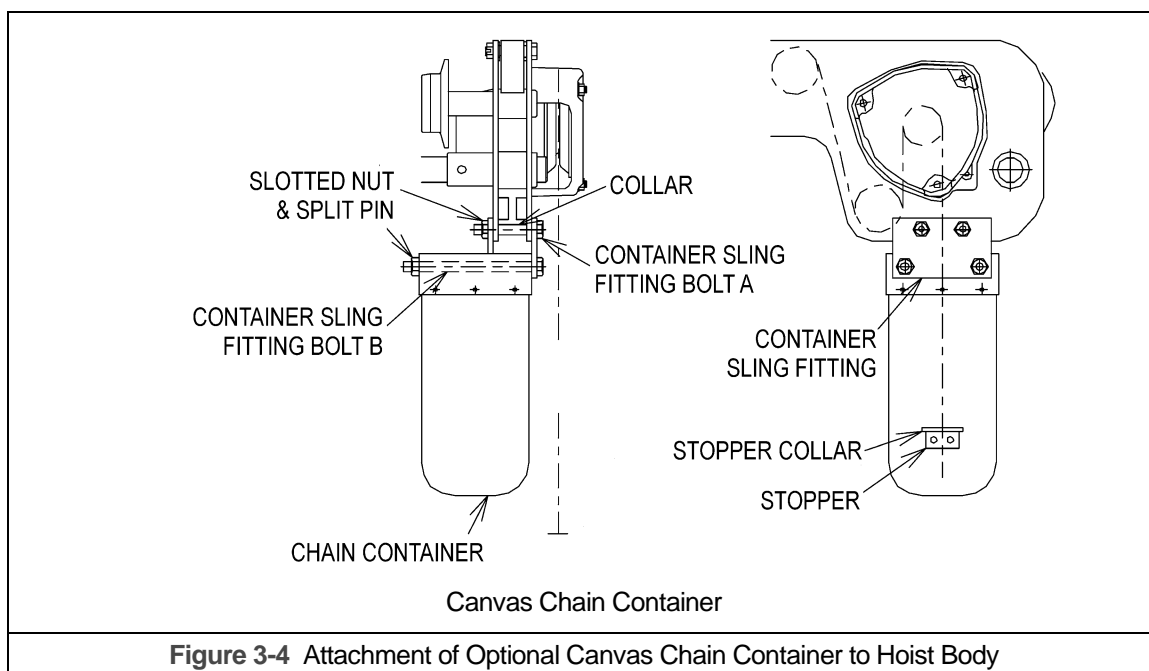

- 3.2.4 When using an optional steel chain container, refer to the assembly drawing and instructions provided with the container for correct assembly and attachment.

3.3 Installation of Trolley Hoist onto Beam

- 3.3.1 Assemble and adjust the trolley hoist before attempting to install it on the beam.
- 3.3.2 Preferred Method – Sliding the trolley hoist onto the traversing beam from the beam end is the most convenient and recommended method. If the trolley hoist can be mounted from the end of the beam then: Remove the trolley end-stop from the beam and set the trolley hoist on the beam from the end. Securely re-install the trolley end stop on the beam. See Figure 3-5.

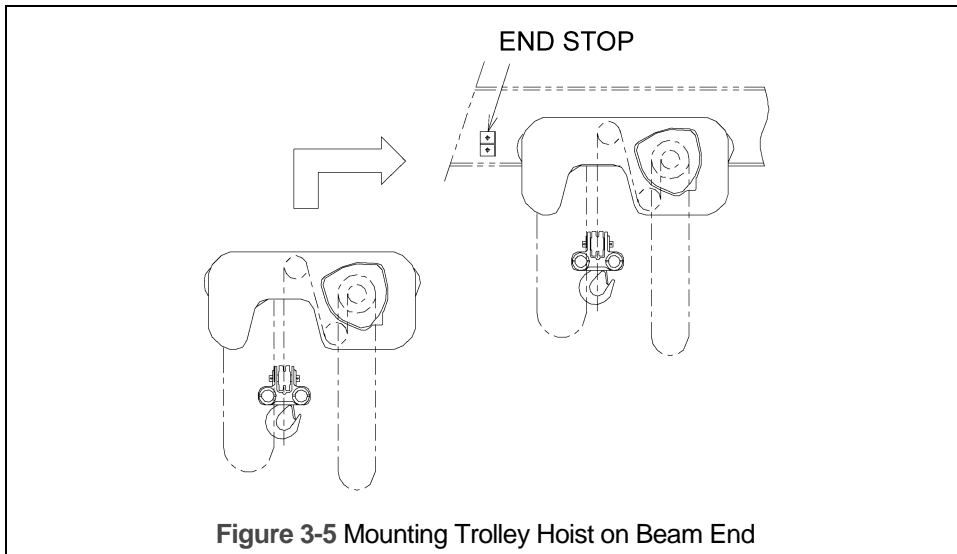

3.3.3 Optional Method for the Trolley Hoist – If the trolley hoist cannot be mounted from the end of the beam, complete the installation as follows:

- 1) Remove the Shaft Stopper Pin from Suspension Shaft (See Figure 3-6).
- 2) If possible remove the outside Adjusting spacers and Reinsert the Shaft Stopper Pin. Spread the trolley side plates apart.
- 3) Lift the trolley onto the beam so that Side Plate G (handwheel side) rests on the beam's flange.
- 4) Hold Side Plate G securely so that it does not come off the beam. Then push Side Plate S (hoist side) onto the beam so that all four wheels rest on the beam's flange.
- 5) Replace the Outside Adjusting Spacers and the Shaft Stopper Pin. Insert Split Pin, bend the Split Pin securely.

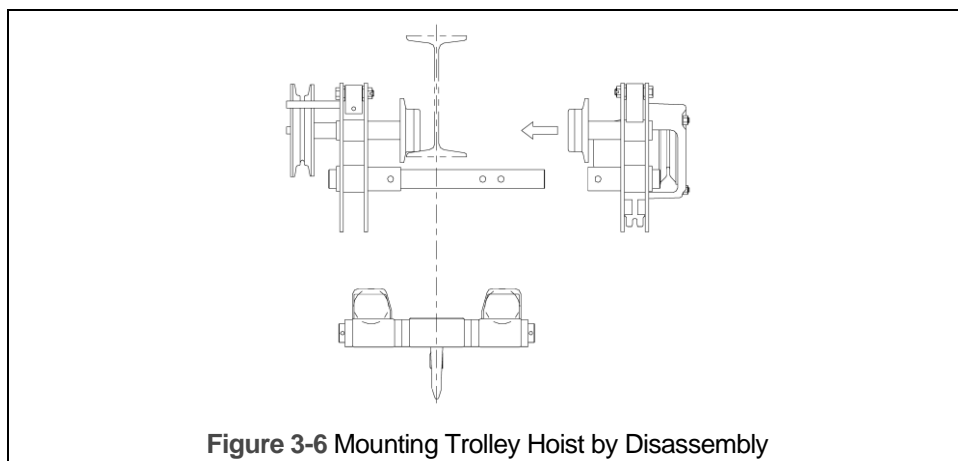

3.4 Preoperational Checks and Trial Operation

- 3.4.1 **⚠️ WARNING** Confirm the adequacy of the rated capacity for all slings, chains, wire ropes and all other lifting attachments before use. Inspect all load suspension members for damage prior to use and replace or repair all damaged parts.
- 3.4.2 **⚠️ WARNING** Verify and correct all chain irregularities prior to operating the trolley hoist. Refer to Section 3.1.
- 3.4.3 Measure and record the “k” dimension of the hook on the trolley hoist. See Table 5-4 under Section 5, “Inspection”.
- 3.4.4 Record the trolley hoist's Code, Lot and Serial Number (from the name plate on the hoist; see Section 9) in the space provided on the cover of this manual.
- 3.4.5 Ensure that the trolley hoist is properly installed on the beam, and stops for the trolley hoist are correctly positioned and securely installed on the beam.
- 3.4.6 Ensure that all nuts, bolts and split pins (cotter pins) are sufficiently fastened.
- 3.4.7 Confirm proper operation.
- Before operating read and become familiar with Section 4 - Operation.
 - Before operating ensure that the trolley hoist meets the Inspection, Testing and Maintenance requirements of ANSI/ASME B30.16.
 - Before operating ensure that nothing will interfere with the full range of the trolley hoist's operation.
- 3.4.8 Proceed with trial operation to confirm proper operation.
- Operate the trolley hoist through its full range of motion. Make sure the trolley hoist runs smoothly and does not bind.
 - Perform inspections per Section 5.3, “Frequent Inspections”.

4.0 Operation

4.1 Introduction

DANGER

DO NOT WALK UNDER A SUSPENDED LOAD

WARNING

HOIST OPERATORS SHALL BE REQUIRED TO READ THE OPERATION SECTION OF THIS MANUAL, THE WARNINGS CONTAINED IN THIS MANUAL, INSTRUCTION AND WARNING LABELS ON THE HOIST OR LIFTING SYSTEM, AND THE OPERATION SECTIONS OF ANSI/ASME B30.16 and ANSI/ASME B30.10. THE OPERATOR SHALL ALSO BE REQUIRED TO BE FAMILIAR WITH THE HOIST AND HOIST CONTROLS BEFORE BEING AUTHORIZED TO OPERATE THE HOIST OR LIFTING SYSTEM.

HOIST OPERATORS SHOULD BE TRAINED IN PROPER RIGGING PROCEDURES FOR THE ATTACHMENT OF LOADS TO THE HOIST HOOK.

HOIST OPERATORS SHOULD BE TRAINED TO BE AWARE OF POTENTIAL MALFUNCTIONS OF THE EQUIPMENT THAT REQUIRE ADJUSTMENT OR REPAIR, AND TO BE INSTRUCTED TO STOP OPERATION IF SUCH MALFUNCTIONS OCCUR, AND TO IMMEDIATELY ADVISE THEIR SUPERVISOR SO CORRECTIVE ACTION CAN BE TAKEN.

HOIST OPERATORS SHOULD HAVE NORMAL DEPTH PERCEPTION, FIELD OF VISION, REACTION TIME, MANUAL DEXTERITY, AND COORDINATION.

HOIST OPERATORS SHOULD **NOT** HAVE A HISTORY OF OR BE PRONE TO SEIZURES, LOSS OF PHYSICAL CONTROL, PHYSICAL DEFECTS, OR EMOTIONAL INSTABILITY THAT COULD RESULT IN ACTIONS OF THE OPERATOR BEING A HAZARD TO THE OPERATOR OR TO OTHERS.

HOIST OPERATORS SHOULD **NOT** OPERATE A HOIST OR LIFTING SYSTEM WHEN UNDER THE INFLUENCE OF ALCOHOL, DRUGS, OR MEDICATION.

NOTICE

- Read ANSI/ASME B30.16 and ANSI/ASME B30.10.
- Read the hoist manufacturer's Operating and Maintenance Instructions.
- Read all labels attached to equipment.

The operation of a hoist involves more than activating the hoist's controls. Per the ANSI/ASME B30 standards, the use of a hoist is subject to certain hazards that cannot be mitigated by engineered features, but only by the exercise of intelligence, care, common sense, and experience in anticipating the effects and results of activating the hoist's controls. Use this guidance in conjunction with other warnings, cautions, and notices in this manual to govern the operation and use of your hoist.

4.2 Shall's and Shall Not's for Operation

WARNING

Improper operation of a hoist can create a potentially hazardous situation which, if not avoided, could result in death or serious injury, and substantial property damage. To avoid such a potentially hazardous situation **THE OPERATOR SHALL:**

- **NOT** lift more than rated load for the hoist.
- **NOT** use damaged hoist or hoist that is not working properly.
- **NOT** use hoist with twisted, kinked, damaged, or worn chain.
- **NOT** use hoist if the bottom hook is capsized (multiple fall hoists - see Section 3.1).
- **NOT** use the hoist to lift, support, or transport people.
- **NOT** lift loads over people.
- **NOT** apply load unless load chain is properly seated in the load sheave (and idle sheave for hoist with multiple chain falls).
- **NOT** use the hoist in such a way that could result in shock or impact loads being applied to the hoist.
- **NOT** attempt to lengthen the load chain or repair damaged load chain.
- **NOT** operate hoist when it is restricted from forming a straight line from hook to hook in the direction of loading.
- **NOT** use load chain as a sling or wrap load chain around load.
- **NOT** apply load if binding prevents equal loading on all load-supporting chains.
- **NOT** operate beyond the limits of the load chain travel.
- **NOT** support load on hook tip unless hook is designed for tip loading.
- **NOT** use in a way that causes either hook to be side-loaded.
- **NOT** leave load supported by the hoist unattended unless specific precautions have been taken.
- **NOT** allow the chain, or hook to be used as an electrical or welding ground.
- **NOT** allow the chain, or hook to be touched by a live welding electrode.
- **NOT** remove or obscure the warnings on the hoist.
- **NOT** operate a hoist on which the safety placards or decals are missing or illegible.
- Be familiar with operating controls, procedures, and warnings.
- Make sure the unit is securely attached to a suitable support before applying load.
- Make sure load slings or other approved single attachments are properly sized, rigged, and seated in the hook saddle.
- Take up slack carefully - make sure load is balanced and load-holding action is secure before continuing.
- Make sure all persons stay clear of the supported load.
- Protect the hoist's load chain from weld splatter or other damaging contaminants.
- Report Malfunctions or unusual performances (including unusual noises) of the hoist and remove the hoist from service until the malfunction or unusual performance is resolved.
- Warn personnel before lifting or moving a load.
- Warn personnel of an approaching load.

⚠ CAUTION

Improper operation of a hoist can create a potentially hazardous situation which, if not avoided, could result in minor or moderate injury, or property damage. To avoid such a potentially hazardous situation **THE OPERATOR SHALL:**

- Maintain a firm footing or be otherwise secured when operating the hoist.
- Check brake function by tensioning the hoist prior to each lift operation.
- Use hook latches. Latches are to retain slings, chains, etc. under slack conditions only.
- Make sure the hook latches are closed and not supporting any parts of the load.
- Make sure the load is free to move and will clear all obstructions.
- Avoid swinging the load or hook.
- Make sure hook travel is in the same direction as shown on controls.
- Inspect the hoist regularly, replace damaged or worn parts, and keep appropriate records of maintenance.
- Use the hoist manufacturer's recommended parts when repairing the unit.
- Lubricate load chain per hoist manufacturer's recommendations.
- **NOT** use the hoist load limiting or warning device to measure load.
- **NOT** allow your attention to be diverted from operating the hoist.
- **NOT** allow the hoist to be subjected to sharp contact with other hoists, structures, or objects through misuse.
- **NOT** adjust or repair the hoist unless qualified to perform such adjustments or repair.

4.3 Hoist Operation

- 1) Face the Hoist hand chain wheel side of the trolley hoist.
- 2) To raise the load, pull Hoist hand chain clockwise.
- 3) To lower the load, pull Hoist hand chain counterclockwise.

NOTE: The clicking sound of the pawl when a load is being raised indicates normal operation.

- 4) Reference Table 4-1 and "Owner's Manual for Manual Chain Hoist CB Series Model M3 1/2 Ton through 20 Ton Capacity" for further hoist information.

Cap. (Tons)	SHB Product Code	CB Product Code
1	SHB010	CB005
2	SHB020	CB015
3	SHB030	CB020
5	SHB050	CB025
8	SHB080	CB100
10	SHB100	CB100

4.4 Trolley Operation

- 1) For Plain Trolley, movement is controlled by pushing/pulling on the load or the hook of the attached hoist.
- 2) For Geared Trolley, when facing Trolley hand chain wheel:
 - Pull down on the right side of Trolley hand chain (Clockwise Rotation) to move the Trolley left.
 - Pull down on the left side of Trolley hand chain (Counterclockwise Rotation) to move the Trolley right.
- 3)  **CAUTION** Avoid collisions with the end stops or other Trolleys. Damage may result.

5.0 Inspection

5.1 General

5.1.1 The inspection procedure herein is based on ANSI/ASME B30.16. The following definitions are from ANSI/ASME B30.16 and pertain to the inspection procedure below.

- **Designated Person** – a person selected or assigned as being competent to perform the specific duties to which he/she is assigned.
- **Qualified Person** – a person who, by possession of a recognized degree or certificate of professional standing, or who, by extensive knowledge, training, and experience, has successfully demonstrated the ability to solve or resolve problems relating to the subject matter and work.
- **Normal Service** – that distributed service which involves operation with randomly distributed loads within the rated load limit, or uniform loads less than 65% of rated load for not more than 15% of the time.
- **Heavy Service** – that service which involves operation within the rated load limit which exceeds normal service.
- **Severe Service** – that service which involves normal or heavy service with abnormal operating conditions.

5.2 Inspection Classification

5.2.1 Initial Inspection – prior to initial use, all new, altered, or modified hoists shall be inspected by a designated person to ensure compliance with the applicable provisions of this manual.

5.2.2 Inspection Classification – the inspection procedure for hoists in regular service is divided into two general classifications based upon the intervals at which inspection should be performed. The intervals in turn are dependent upon the nature of the critical components of the hoist and the degree of their exposure to wear, deterioration, or malfunction. The two general classifications are herein designated as FREQUENT and PERIODIC, with respective intervals between inspections as defined below.

5.2.3 FREQUENT Inspection – visual examinations by the operator or other designated personnel with intervals per the following criteria:

- Normal service – monthly
- Heavy service – weekly to monthly
- Severe service – daily to weekly
- Special or infrequent service – as recommended by a qualified person before and after each occurrence.

5.2.4 PERIODIC Inspection – visual inspection by a designated person with intervals per the following criteria:

- Normal service – yearly
- Heavy service – semiannually
- Severe service – quarterly
- Special or infrequent service – as recommended by a qualified person before the first such occurrence and as directed by the qualified person for any subsequent occurrences.

5.3 Frequent Inspection

- 5.3.1 Inspections should be made on a FREQUENT basis in accordance with Table 5-1, "Frequent Inspection." Included in these FREQUENT Inspections are observations made during operation for any defects or damage that might appear between Periodic Inspections. Evaluation and resolution of the results of FREQUENT Inspections shall be made by a designated person such that the hoist is maintained in safe working condition.

Table 5-1 Frequent Inspection
All functional operating mechanisms for proper operation and adjustment, maladjustment and unusual sounds.
Hoist braking system for proper operation
Hooks and latches in accordance with ANSI/ASME B30.10
Hook latch operation
Load chain in accordance with Section 5.7
Load chain reeving for compliance with Section 3.1 and 6.1
Hoist support for damage
Connection points between Hoist and Trolley in accordance with ANSI/ASME B30.16

5.4 Periodic Inspection

- 5.4.1 Inspections should be made on a PERIODIC basis in accordance with Table 5-2, "Periodic Inspection." Evaluation and resolution of the results of PERIODIC Inspections shall be made by a designated person such that the hoist is maintained in safe working condition.
- 5.4.2 For inspections where load suspension parts of the hoist are disassembled, a load test per ANSI/ASME B30.16 must be performed on the hoist after it is re-assembled and prior to its return to service.

Table 5-2 Periodic Inspection
Requirements of frequent inspection.
Evidence of loose bolts, nuts, pins, or rivets.
Evidence of worn, corroded, cracked, or distorted parts such as load blocks, suspension housing, chain attachments, clevises, yokes, suspension bolts, shafts, gears, bearings, pins, rollers, locking and clamping devices, wheels, and bumpers.
Evidence of damage to hook retaining nuts or collars and pins, and welds or rivets used to secure the retaining members.
Evidence of damage or excessive wear of load and idler sheaves.
Evidence of worn, glazed or oil contaminated friction disks; worn pawls, cams or ratchet; corroded, stretched, or broken pawl springs in brake mechanism.
Evidence of damage to supporting structure.
Function label on hoist for legibility.
Warning label properly attached to the hoist and legible (see Section 1.2).
End connection of load chain.

5.5 Occasionally Used Hoists

- 5.5.1 Trolley-hoists that are used infrequently shall be inspected as follows prior to placing in service:
- Trolley-hoist Idle More Than 1 Month, Less Than 1 Year: Inspect per FREQUENT Inspection criteria in Section 5.3.
 - Trolley-hoist Idle More Than 1 Year: Inspect per PERIODIC Inspection criteria in Section 5.4.

5.6 Inspection Records

- 5.6.1 Dated inspection reports and records should be maintained at time intervals corresponding to those that apply for the trolley-hoist's PERIODIC interval per Section 5.2.4. These records should be stored where they are available to personnel involved with the inspection, maintenance, or operation of the hoist.
- 5.6.2 A long range chain inspection program should be established and should include records of examination of chains removed from service so a relationship can be established between visual observation and actual condition of the chain.

5.7 Inspection Methods and Criteria

- 5.7.1 This section covers the inspection of specific items. The list of items in this section is based on those listed in ANSI/ASME B30.16 for the Frequent and Periodic Inspection.
- 5.7.2 Frequent Inspection - Not intended to involve disassembly of the hoist. Disassembly for further inspection would be required if only if frequent inspection results so indicate. Disassembly and further inspection should only be performed by a qualified person trained in the disassembly and re-assembly of the hoist.
- 5.7.3 Periodic Inspection - Disassembly of the hoist is required. Disassembly should only be performed by a qualified person trained in the disassembly and re-assembly of the hoist.
- 5.7.4 In accordance with ANSI/ASME B30.16, these inspections are not intended to involve disassembly of the trolley. Rather, disassembly for further inspection would be required if frequent or periodic inspection results so indicate. Such disassembly and further inspection should only be performed by a qualified person trained in the disassembly and re-assembly of the trolley.

Table 5-3 Hoist Inspection Methods and Criteria

Item	Method	Discard Limit/Criteria	Action
Functional operating mechanisms.	Visual, Auditory	Mechanisms should be properly adjusted and should not produce unusual sounds when operated. Components should not be deformed, scarred, or show significant wear.	Repair or replace as required.
Hook – Stretch	Measure	The "k" dimension should not be greater than 1.05 times that measured and recorded at the time of purchase (See Section 3.4). If recorded "k" values are not available for hooks when new, use nominal "k" values from Table 5-4.	Replace.
Hook – Fretting wear	Measure	The "u" and "t" dimensions should not be less than discard value listed in Table 5-4.	Replace.
Hook – Surface Condition	Visual	Should be free of gouges, deep nicks, dents, weld splatter, and significant corrosion.	Replace.
Hook – Deformation	Visual	Should be free of twists and deformations. See Figure 5-1.	Replace.

Table 5-3 Hoist Inspection Methods and Criteria

Item	Method	Discard Limit/Criteria	Action
Hook – Bent Shank or Neck	Visual	Shank and neck portions of hook should be free of deformations.	Replace.
Hook – Swivel	Visual, Function	Bearing parts and surfaces should not show significant wear, and should be free of dirt, grime, and deformations. Hook should rotate freely with no roughness. See Figure 5-1.	Clean/lubricate, or replace as required.
Hook – Yoke Assembly	Visual	Should be free of significant rust, weld splatter, nicks, and gouges. Holes should not be elongated, fasteners should not be loose, and there should be no gap between mating parts.	Tighten or replace as required.
Hook – Idle Sheave and Shaft (on Lower Suspension Shaft)	Visual, Function	Pockets of Idle Sheave should be free of significant wear. Idle Sheave surfaces should be free of nicks, gouges, dirt, and grime. Bearing parts and surfaces of Idle Sheave and Axle should not show significant wear. Idle Sheave should rotate freely with no roughness or significant free play.	Clean/lubricate, or replace as required.
Hook – Hook Latches	Visual, Function	Latch should not be deformed. Attachment of latch to hook should not be loose. Latch spring should not be missing and should not be weak. Latch movement should not be stiff - when depressed and released latch should snap smartly to its closed position.	Replace.
Hook Suspender - Wear	Measure	The value of "C" dimension should not be greater than the discard value listed in Table 5-7.	Replace.
Load Chain – Pitch and Wire Diameter	Measure	The "P" dimension should not be greater than discard value listed in Table 5-5. The "d" dimension should not be less than discard value listed in Table 5-5.	Replace. Inspect Load Sheave (and Idle Sheave for multiple fall hoists).
Load Chain – Surface Condition	Visual	Should be free of gouges, nicks, dents, weld splatter, and corrosion. Links should not be deformed, and should not show signs of abrasion. Surfaces where links bear on one another should be free of significant wear.	Replace.
Load Chain – Lubrication	Visual, Auditory	Entire surface of each chain link should be coated with lubricant and should be free of dirt and grime. Chain should not emit cracking noise when hoisting a load.	Clean/lubricate (see Section 6.0).
Load Chain – Reeving	Visual	Chain should be reeved /installed properly and free of twists. Refer to Section 3.2.	Reeve/Install chain properly.
Lifting System – Components	Visual, Function	Components should not be deformed, scarred, or show significant wear.	Replace.
Load Sheave	Visual	Pockets of Load Sheave should be clean and free of significant wear.	Replace.
Hand Wheel	Visual	Large wear or deformation on the surface of hand wheel. The hand wheel touches the cover.	Replace.

Table 5-3 Hoist Inspection Methods and Criteria			
Item	Method	Discard Limit/Criteria	Action
Housing and Mechanical Components	Visual, Auditory, Function	Trolley hoist components including suspension shafts, track wheels, track wheel axles, load blocks, suspension housing, chain attachments, clevises, yokes, suspension bolts, shafts, gears, bearings, stripper, pins, rollers, and bumpers should be free of cracks, distortion, significant wear, and corrosion. Evidence of same can be detected visually or via detection of unusual sounds during operation.	Replace.
Chain Guide	Visual	Excessive wear or press mark.	Replace.
Bolts, Nuts and Rivets	Visual, Check with Proper Tool	Bolts, nuts, snap rings, split pins, and rivets should not be loose, deformed, or corroded.	Tighten or replace as required.
Side Plates	Visual	Must be free of significant deformation	Replace.
Track Wheel - Tread	Visual, Measure	Diameter of the inside and outside tread surface should not be less than the discard value shown in Table 5-6.	Replace.
Track Wheel - Gear	Visual	Teeth should not be cracked, damaged, or excessively worn.	Replace.
Upper Suspension Shaft	Visual, Measure	Suspension shaft should not be bent. Diameter should not be worn by 10% or more.	Replace.
Lower Suspension Shaft	Visual, Measure	Suspension shaft should not be bent. Diameter should not be worn by 10% or more.	Replace.
Warning Labels	Visual	Warning Labels should be affixed to the hoist (see Section 1.2) and they should be legible.	Replace.
Trolley Hoist Capacity Label	Visual	The label that indicates the capacity of the hoist should be legible and securely attached to the hoist.	Replace.

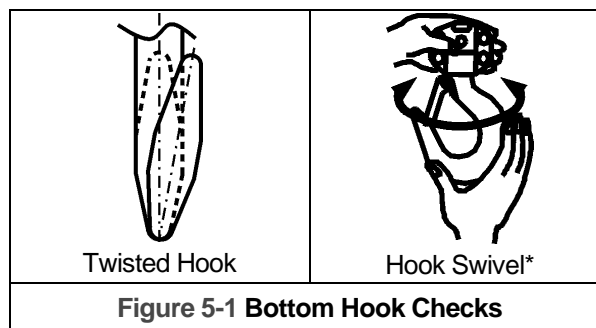

*If the Bottom Hook does not rotate freely, disassemble the Suspender A and clean the surface between the Suspender A and the Bottom Hook. Lubricate with Shell Alvania S3 grease or equivalent. If the Bottom Hook does not rotate freely after cleaning and lubricating or wear in abnormal manner, replace the entire assembly. See Section 5.7, “Hook – Swivel”.

Rotating the Bottom Hook under load may cause wear between the Suspender A and the Bottom Hook.

⚠ WARNING Be sure to perform the inspections MONTHLY to avoid excessive wear between the Suspender A and the Bottom Hook, as excessive wear may lead to the Bottom Hook disengaging from the Suspender A.

Table 5-4 Bottom Hook Dimensions

"k" Measured When New:

Bottom: _____

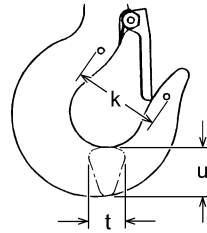

Product Code	Nominal "k" Dimension* inch (mm)	"u" Dimension inch (mm)		"t" Dimension inch (mm)	
		Standard	Discard	Standard	Discard
SHB010	1.92 (48.8)	0.86 (21.8)	0.77 (19.6)	0.63 (16.0)	0.57 (14.4)
SHB020	2.36 (59.9)	1.18 (30.0)	1.06 (27.0)	0.86 (21.8)	0.77 (19.6)
SHB030	2.72 (69.1)	1.48 (37.5)	1.33 (33.8)	1.07 (27.2)	0.97 (24.5)
SHB050	3.06 (77.8)	1.87 (47.5)	1.69 (42.8)	1.36 (34.5)	1.22 (31.1)
SHB080	4.03 (102.3)	2.88 (73.0)	2.23 (56.7)	1.87 (47.5)	1.69 (42.8)
SHB100					

* These values are nominal since the dimension is not controlled to a tolerance. The "k" dimension should be measured when the hook is new - this becomes a reference measurement. Subsequent measurements are compared to this reference to make determinations about hook deformation/stretch. See Section 5.7, "Hooks - Stretch".

Table 5-5 Chain Wear Dimensions

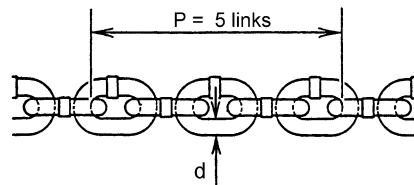

Product Code	"P" Dimension inch (mm)		"d" Dimension inch (mm)	
	Standard	Discard	Standard	Discard
SHB010	2.97 (75.5)	3.06 (77.7)	0.20 (5.0)	0.18 (4.5)
SHB020	4.17 (106.0)	4.30 (109.1)	0.28 (7.1)	0.25 (6.4)
SHB030	4.76 (121.0)	4.91 (124.6)	0.32 (8.0)	0.28 (7.2)
SHB050 SHB080 SHB100	5.35 (136.0)	5.51 (140.0)	0.35 (9.0)	0.32 (8.1)

Table 5-6 Track Wheel Wear Dimensions

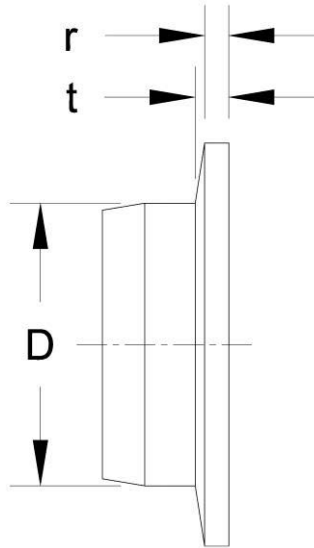

Note: Track wheels are for flat and tapered flanges.

Capacity (Ton)	"D" Dimension inch (mm)		"t" Dimension inch (mm)		"r" Dimension inch (mm)	
	Standard	Discard	Standard	Discard	Standard	Discard
1	2.80 (71)	2.74 (69.5)	0.374 (9.5)	0.264 (6.7)	0.224 (5.7)	0.158 (4.0)
2	3.35 (85)	3.29 (83.5)	0.413 (10.5)	0.291 (7.4)	0.232 (5.9)	0.161 (4.1)
3	3.94 (100)	3.88 (98.5)	0.453 (11.5)	0.319 (8.1)	0.260 (6.6)	0.181 (4.6)
5	4.65 (118)	4.41 (112)	0.591 (15.0)	0.413 (10.5)	0.370 (9.4)	0.260 (6.6)
8	6.1 (155)	5.8 (147.3)	0.559 (14.2)	0.53 (13.5)	0.433 (11.0)	0.411 (10.5)
10						

Table 5-7 Suspender A - Bottom Hook Wear Dimensions

"A" Measured When New*:

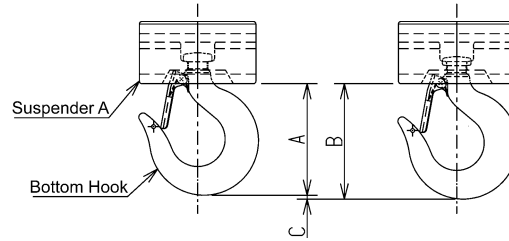

Product Code	Nominal "A" Dimension** inch (mm)	"C" Dimension*** inch (mm)
		Discard
SHB010	3.39 (86)	0.12 (3)
SHB020	4.57 (116)	0.12 (3)
SHB030	5.33 (135.5)	0.12 (3)
SHB050	6.32 (160.5)	0.12 (3)
SHB080	9.27 (235.5)	0.20 (5)
SHB100		

* Measure and record the "A" dimension, the distance between the Suspender A and the Bottom Hook when the hoist is new. This becomes a reference measurement. Subsequent measurements are compared to this reference measurement in order to determine wear.

** These values are nominal since the dimension is not controlled to a tolerance.

*** Measure and record the distance between the Suspender A and the Bottom Hook (same as the initial inspection measurement); this will be the "B" dimension. The difference between the "B" and "A" will be the "C" dimension. When the value of "C" exceeds the discard values given in the Table 5-7, replace the Suspender A and the Bottom Hook.

6.0 Maintenance and Handling

6.1 Lubrication

6.1.1 Load Chain

- For longer life, the load chain should be lubricated.
- The load chain lubrication should be accomplished after cleaning the load chain with an acid free cleaning solution.
- Apply Harrington lubricating grease (Part No. ER1BS1951) or an equivalent to industrial general lithium grease, NLGI No. 0, to the bearing surfaces of the load chain links as indicated by the shaded areas in Figure 6-1. Also apply the grease to the areas of the load chain (shaded areas in Figure 6-1) that contact the load sheave. Insure that the grease is applied to the contact areas in the load sheave pockets.
- Machine or gear oil (grade ISO VG 46 or 68 oil or equivalent) may be used as an alternative lubricant but must be applied more frequently.

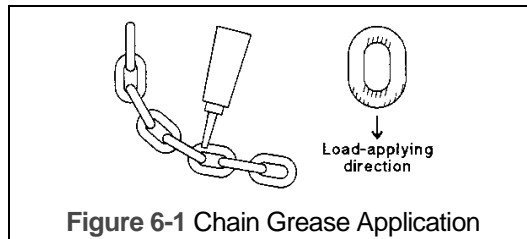

- The chain should be lubricated every 3 months (more frequently for heavier usage or severe conditions).
- For dusty environments, it is acceptable to substitute a dry lubricant.

6.1.2 Hooks and Suspension Components:

- Hooks – Bearings should be cleaned and lubricated at least once per year for normal usage. Clean and lubricate more frequently for heavier usage or severe conditions.
- Suspension Pins - Lubricate the chain pin and the top pin at least twice per year for normal usage; more frequently for heavier usage or severe conditions.

6.1.3 Applying Grease to Sheaves and Idle Wheels:

- Remove old grease and replace the new grease (NLGI No. 2), at annual inspection.
- Temperature range of standard grease is -20°C (-4°F) to + 60°C (140°F). If the hoist is used at temperatures below -20°C (-4°F) or above 60°C (140°F), consult the manufacturer or dealer since some parts should be changed.

Table 6-1 General Lubrication			
Parts to be Lubricated	Name of Oil	Amount of Lubrication and Lubricating Method	Frequency of Lubrication
Mechanical Brake Parts: Ratchet Disc, Pawl Pin, Screw parts of Pinion	Machine or Gear Oil	Wipe off oil with waste cloth after applying proper amount of oil.	When the hand pull becomes extremely heavy in lowering operations.

6.1.4 Hoist:

- Follow the hoist lubrication instructions in the “Owner’s Manual for Manual Chain Hoist CB Series Model M3 1/2 Ton through 20 Ton Capacity” for further hoist information.

6.1.5 Trolley:

- Lubricate the following trolley components with NLGI (National Lubricating Grease Institute) #2 or equivalent grease.
- Track Wheel Gear – Clean and re-grease the Track Wheel gears and Hand Wheel output pinion every three months (more frequently for heavier usage or severe conditions). Do not use an excessive amount of grease and avoid getting any grease on the running surfaces of the Track Wheels or the beam.
- Trolley Wheel Bearings do not need to be lubricated and must be replaced if worn or damaged.
- Suspension Pins, Bolts and Shafts – Grease at least twice per year for normal usage (more frequently for heavier usage or severe conditions).

6.2 Storage

6.2.1 **▲ WARNING** : **IMPROPER** chain hoist storage could result in death or serious injury. To avoid these hazards:

- **ALWAYS** store the hoist in a no load condition.
- **ALWAYS** wipe off all dirt and water.
- **ALWAYS** oil the chain, hook pins and hook latches.
- **ALWAYS** hang in a clean and dry place.
- **ALWAYS** check the hoist for abnormalities (according to the regular inspection procedures) when using the hoist after a period of non-use (Refer to Section 5.7).

6.3 Outdoor Installation

- 6.3.1 For trolley hoist installations that are outdoors, the trolley hoist **MUST BE** covered and protected from the weather at all times.
- 6.3.2 Possibility of corrosion on components of the trolley hoist increases for installations where salt air and high humidity are present. The trolley hoist may require more frequent lubrication. Make frequent and regular inspections of the unit’s condition and operation.
- 6.3.3 For trolley hoist installations where temperature variations introduce condensation into the hoist additional inspection and more frequent lubrication may be required.
- 6.3.4 Refer to Section 2.1.2 for allowable environmental conditions.

6.4 Operational Environment

6.4.1 Non-conforming environment

A non-conforming environment is defined as one with any or all of the following.

- Explosive gases or vapor.
- Organic solvents or volatile powder
- Excessive amounts of powder and dust of general substances
- Excessive amount of acids or salts.

7.0 Troubleshooting

WARNING

Read and comply with instructions in this manual and use the trolley hoist properly.

Checking the sounds from the hoist in operation is a critical inspection. Note trolley and hoist sounds during operation.

If a defect is found in the trolley or the hoist, stop using immediately and check the cause of the defect.

Only Trained and competent personnel should inspect and repair the hoist.

Table 7-1 Troubleshooting Guide

Note on proper operation:

- When lifting, the hoist should make clicking sounds when moving the hand wheel.
- When lowering, the hoist should not make clicking sounds when moving the hand wheel.
- Hoist: Follow the Troubleshooting Guide in the “Owner’s Manual for Manual Chain Hoist CB Series Model M3 1/2 Ton through 20 Ton Capacity” for hoist troubleshooting information.

8.0 Warranty

Warranty explanation and terms.

All products sold by Harrington Hoists, Inc. are warranted to be free from defects in material and workmanship from date of shipment by Harrington for the following periods:

- 1 year – Electric and Air Powered Hoists (excluding (N)ER2 Enhanced Features Models and EQ/SEQ Models), Powered Trolleys, Powered Tiger Track Jibs and Gantries, Crane Components, Below the Hook Devices, Spare / Replacement Parts**
- 2 years – Manual Hoists & Trolleys, Beam Clamps**
- 3 years – (N)ER2 Enhanced Features Hoists, EQ/SEQ Hoists, and RY Hoists**
- 5 years – Manual Tiger Track Jibs and Gantries, TNER, EQ/SEQ, and RY Hoist Motor Brakes**
- 10 years – (N)ER2 “The Guardian” Smart Brake**

The product must be used in accordance with manufacturer’s recommendations and must not have been subject to abuse, lack of maintenance, misuse, negligence, or unauthorized repairs or alterations.

Should any defect in material or workmanship occur during the above time period in any product, as determined by Harrington Hoist’s inspection of the product, Harrington Hoists, Inc. agrees, at its discretion, either to replace (not including installation) or repair the part or product free of charge and deliver said item F.O.B. Harrington Hoists, Inc. place of business to customer.

Customer must obtain a Return Goods Authorization as directed by Harrington or Harrington’s published repair center prior to shipping product for warranty evaluation. An explanation of the complaint must accompany the product. Product must be returned freight prepaid. Upon repair, the product will be covered for the remainder of the original warranty period. Replacement parts installed after the original warranty period will only be eligible for replacement (not including installation) for a period of one year from the installation date. If it is determined there is no defect, or that the defect resulted from causes not within the scope of Harrington’s warranty, the customer will be responsible for the costs of returning the product.

Harrington Hoists, Inc. disclaims any and all other warranties of any kind expressed or implied as to the product’s merchantability or fitness for a particular application. Harrington will not be liable for death, injuries to persons or property or for incidental, contingent, special or consequential damages, loss or expense arising in connection with the use or inability whatever, regardless of whether damage, loss or expense results from any act or failure to act by Harrington, whether negligent or willful, or from any other reason.

9.0 Parts List

When ordering Parts, please provide the Trolley Hoist code number, lot number and serial number located on the Trolley Hoist nameplate (see fig. below).

Serial numbers will end with either a numeric character or an 'H'. Serial numbers ending in 'H' represent product of the US.

Reminder: Per sections 1.1 and 3.4.4, to aid in ordering Parts and Product Support, record the Trolley Hoist code number, lot number and serial number in the space provided on the cover of this manual.



The parts list is arranged into the following sections:

Section	Page
9.1 SHB Parts (1 to 5 Ton)	37
9.2 SHB Parts (8 and 10 Ton)	42

9.1 SHB Parts (1 to 5 Ton)

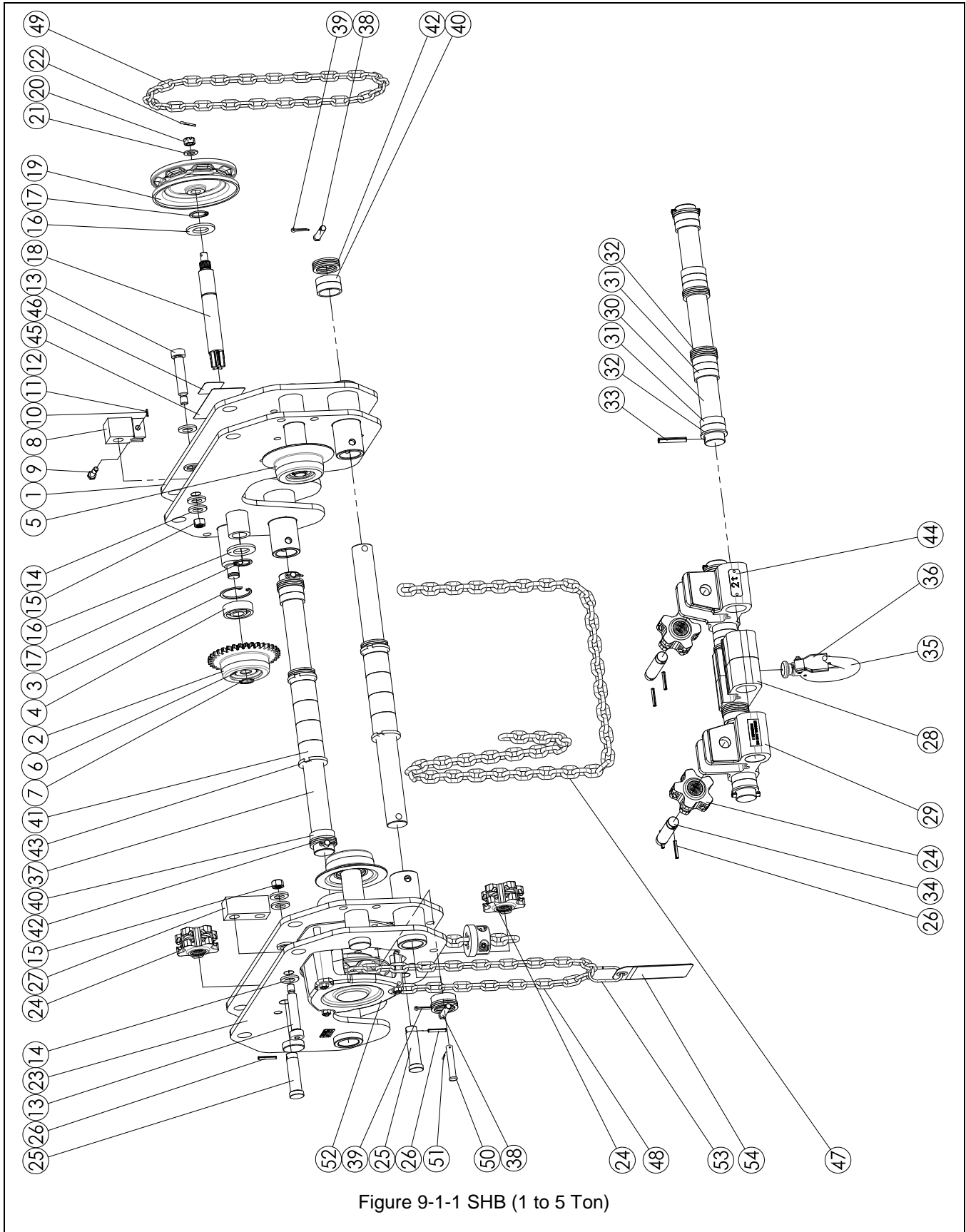

Figure 9-1-1 SHB (1 to 5 Ton)

9.1 SHB Parts (1 to 5 Ton)

Figure No.	Part Name	Parts Per Hoist	1 Ton	2 Ton	3 Ton	5 Ton
1	Side Plate G Assembly *	1	72CG0105112	72CG0205112	72CG0305112	74CG0505111
2	Track Wheel G	1	T3G1101010	T3G1101020	T3G1101030	T3G1101050
3	Snap Ring	4	9047115	9047120	9047125	9047135
4	Ball Bearing	4	9000702	9000704	9000705	9000707
5	Track Wheel S	3	T3P1102010	T3P1102020	T3P1102030	T3P1102050
6	Track Wheel Washer	4	MS104010	MS104020	MS104030	MS104050
7	Snap Ring	4	9047115	9047120	9047125	9047135
8	Connection Yoke C	1	72CG0109126	72CG0209126	72CG0309126	74CG1009135
9	Chain Pin	1	C3BA00590411	C3BA01590411	C3BA02090411	C3BA05090411
10	Spring Pin	1	9148125	9148154	9148157	
11	Slotted Nut	1				M2049020
12	Split Pin	1				9009412
13	Shoulder Bolt	2	9016101	9016102	9016103	9016104
14	Flat Washer	2	9012515	9012517 (3)	9012519 (4)	9012521 (3)
15	Lock Nut	2	9016201	9016202	9016203	9016204
16	Plain Washer	2	9012521	9012521	9012521	9012521
17	Snap Ring	2	9047126	9047126	9047126	9047126
18	Pinion	1	72CG0109134	72CG0209134	72CG0309134	72CG0509134
19	Hand Wheel	1	T5GA01091231		T7GA05091231	
20	Slotted Nut	1	J1NL0011012	J1NL0011012	J1NL0011012	J1NL0011012
21	Plain Washer	1	9012515	9012515	9012515	9012515
22	Split Pin	1	9009424	9009424	9009424	9009424
23	Side Plate S Assembly *	1	72CG0105113	72CG0205113	72CG0305113	74CG0505112
24	Idle Sheave	4	E5FS005L10511	ES1051020L	72CG0301142	C3BA05010512
25	Top Idle Sheave Shaft	2	72CG01091433H	72CG02091433H	72CG03091433H	74CG05091162H
26	Spring Pin	6	9148157	9148191	91481108	91481110
27	Suspender C	1	72CG0109145	72CG0209145	72CG0309145	74CG1009134
28	Suspender A	2	72CG0109161	72CG0209161	72CG0309161	74CG0509201
29	Suspender B	2	72CG0109162	72CG0209162	72CG0309162	74CG0509202
30*	Lower Shaft	2	74SH0109563	74SH0209563	74SH0309563	74SH0509563
31	Thick Spacer	(AR)	MSF116010 (12)	T7G116030 (4)	MSF116030 (16)	74SH0509583 (8)
32	Thin Spacer	(AR)	MSF117010 (30)	MSF117020 (24)	T6G120050 (24)	74SH0509584 (22)
33	Spring Pin	4	9148110	91481124	91481170	91481170
34	Bottom Idle Sheave Shaft	2	72CG0109169	72CG0209169	72CG0309169	74CG0509207
35	Bottom Hook Assembly	1	M3021A010	M3021A020	M3021030	M3021050
36	Hook Latch Assembly	1	CF071010	CF071020	CF071030	M3072050
37*	Upper Shaft	2	74SH0109581	74SH0209581	74SH0309581	74SH0509581
38	Shaft Stopper Pin	4	T6G156020	MS164020	MS164030	MS164050
39	Split Pin	4	9009432	9009432	9009433	9009433
40	Thick Spacer	(AR)	MSF116010 (10)	MSF116030 (8)	MSF116030 (8)	74SH0509583 (34)
41	Fixing Spacer	(AR)	MSF182010 (4)	MSF182020 (8)	74SG0309583 (8)	-

* Not a replacement part. Shown for assembly reference only

9.1 SHB Parts (1 to 5 Ton)

Figure No.	Part Name	Parts Per Hoist	1 Ton	2 Ton	3 Ton	5 Ton
42	Thin Spacer	(AR)	MSF117010 (10)	MSF117020 (20)	T6G120050 (22)	74SH0509584 (18)
43	Thin Spacer C	4	74CG0109853	-	-	-
44	Name Plate – Hook Cap.	1	72CG0109802	73CG0209802	73CG0309802	73CG0509802
45	Name Plate B – SHB	1	80522			
46	Name Plate C – SHB Cap.	1	MR2SHM10S9A7	MR2SHM20S9A7	MR2SHM30S9A7	MR2SHM50S9A7
47	Load Chain	1	LCCF005	LCC3015	LCC3020	LCC3025
48	Hoist Hand Chain	1	HCCF005	HCCF005	HCCF005	HCCF005
49	Trolley Hand Chain	1	HCCF005	HCCF005	HCCF005	HCCF005
50	Stopper Pin	1	M3177005	M3177015	M3177020	MS164050
51	Split Pin	1	9009411	9009413	9009413	9009433
52	Chain Hoist Body	1	CB005	CB015	CB020	CB025
53	Chain Stopper Link	1	L5BA0329045			
54	Warning Tag	1	80146			

* **Extended Flange Range Kits:** Kit includes 2 Upper Shafts, 2 Lower Shafts & Fixing Spacers as Required

Model	Flange Range	Kit Part Number
SHB010	6.43" thru 12.0"	7074601
SHB020	8.04" thru 12.0"	7074701
SHB030	8.04" thru 12.0"	7074801
SHB050	8.04" thru 12.0"	7074901

9.1 SHB Parts (1 to 5 Ton Chain Containers – Optional)

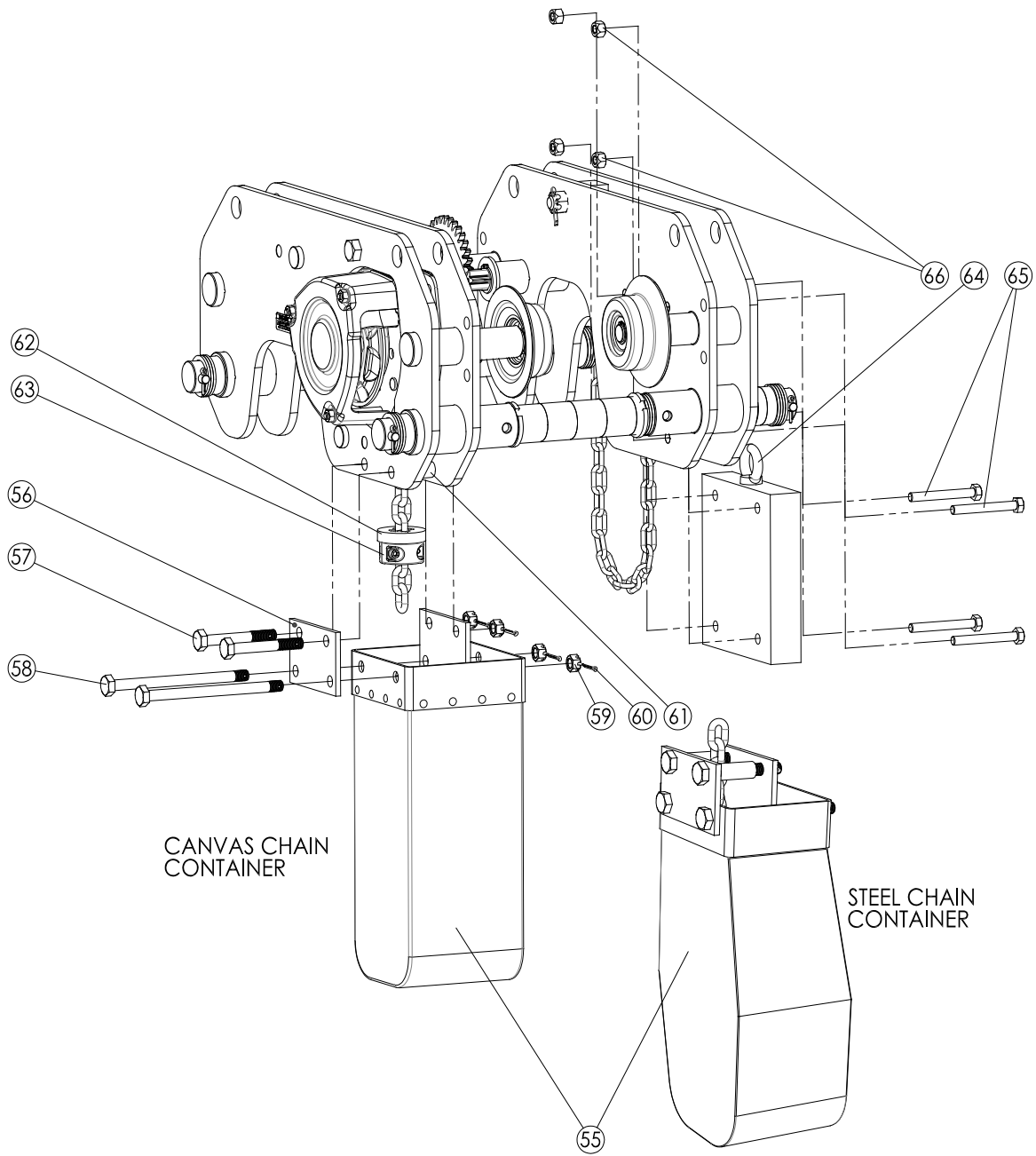

Figure 9-1-2 Canvas Chain Container Parts (1 to 5 Ton)

9.1 SHB Parts (1 to 5 Ton Chain Containers - Optional)

Figure No.	Part Name	Parts Per Hoist	1 Ton	2 Ton	3 Ton	5 Ton
Figure 9-1-2	Canvas Chain Container Assy (Optional)	1	7039801 (13-ft)	7039802 (13-ft)	7039803 (13-ft)	7039807 (20-ft)
			7039804 (23-ft)	7039805 (23-ft)	7039806 (23-ft)	7039808 (30-ft)
55	Canvas Chain Container	1	72BD0105101 (13-ft)	72BD0205101 (13-ft)	72BD0205102 (13-ft)	72BD0505101 (20-ft)
			72BD0105102 (23-ft)	72BD0205102 (23-ft)	72BD0305102 (23-ft)	72BD0505102 (30-ft)
56	Chain Container Suspender	2	72BD0109301	72BD0209301	72BD0209301	72BD0509301
57	Container Suspender Bolt A	2	72BD0109201	72BD0209201	72BD0309201	72BD0509201
58	Container Suspender Bolt B	2	72BA0109202	72BA0209202	72BA0209202 (13-ft)	72BA0509202
					72BA0309202 (23-ft)	
59	Slotted Nut	4	J1NL001-10120	J1NL001-10120	J1NL001-10120	J1NL001-10160
60	Split Pin	4	9009424	9009424	9009424	9009437
61	Spacer	2	72BD0109203	72BD0209203	72BD0309203	72BD0509203
62	Stopper Spacer	1	72BD0109401	72BD0209401	72BD0309401	72BD0509401
63	Stopper Assembly	1	ER1CS1041	ER1DS1041	ER1DS1041	ER1ES1041
Figure 9-1-2	Steel Chain Container Assy (Optional)	1	7039901 (20-ft)	7039903 (20-ft)	7039905 (20-ft)	7039907 (20-ft)
			7039902 (30-ft)	7039904 (30-ft)	7039906 (30-ft)	7039908 (30-ft)
55	Steel Chain Container	1	72BA0105101 (20-ft)	72BA0205101 (20-ft)	72BA0305101 (20-ft)	72BA0505101 (20-ft)
			72BA0105102 (30-ft)	72BA0205102 (30-ft)	72BA0305102 (30-ft)	72BA0505102 (30-ft)
56	Chain Container Suspender	2	72BD0109301	72BD0209301	72BD0209301	72BD0509301
57	Container Suspender Bolt A	2	72BD0109201	72BD0209201	72BD0309201	72BD0509201
58	Container Suspender Bolt B	2	72BD0109202	72BD0209202	72BD0209202 (20-ft)	72BD0509202
					72BD0309202 (30-ft)	
59	Slotted Nut	4	J1NL001-10120	J1NL001-10120	J1NL001-10120	J1NL001-10160
60	Split Pin	4	9009424	9009424	9009424	9009437
61	Spacer	2	72BD0109203	72BD0209203	72BD0309203	72BD0509203
62	Stopper Spacer	1	72BD0109401	72BD0209401	72BD0309401	72BD0509401
63	Stopper Assembly	1	ER1CS1041	ER1DS1041	ER1DS1041	ER1ES1041
64*	Balancer	1	72BD01094021H	72BD02094021H	72BD03094021H	74CG05095011H
65*	Hexagon Head Bolt	4	9093128	9093131	9093133	9093135
66*	U Nut	4	J1NU00110100	J1NU00110100	J1NU00110100	J1NU00110100

AR = Quantities are shown in the parentheses next to part numbers.

* These items not required for

- 1t lifts less than 15'.
- 2t and 3t lifts less than 16'

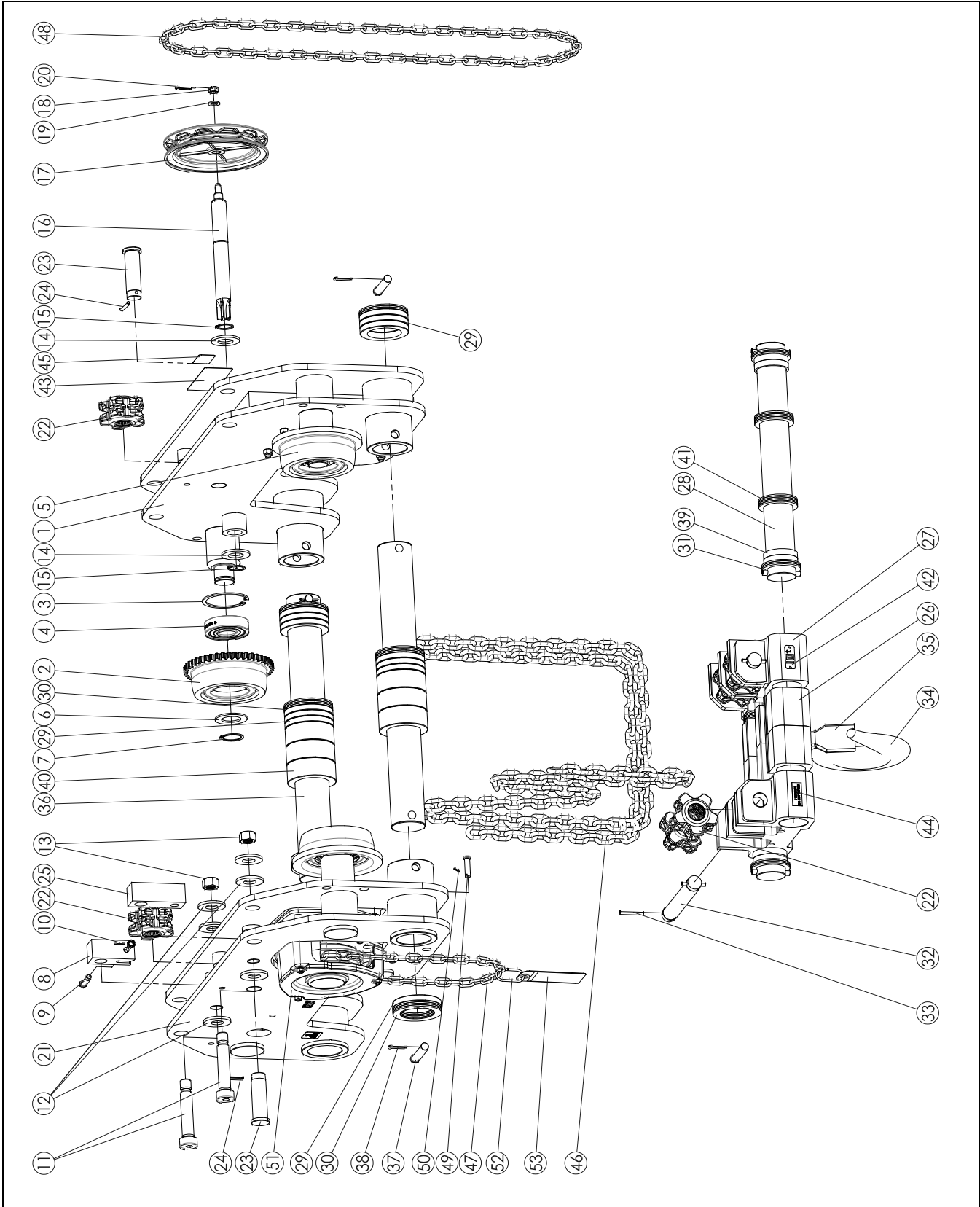

Figure 9-2-1 SHB (8 to 10 Ton)

9.2 SHB Parts (8 and 10 Ton)

Figure No.	Part Name	Parts Per Hoist	8 Ton	10 Ton
1	Side Plate G Assembly *	1	74CG1005111	
2	Track Wheel G	1	T3G1101075	
3	Snap Ring	4	9047140	
4	Ball Bearing	4	9000708	
5	Track Wheel S	3	T3G1102075	
6	Track Wheel Washer	4	T3G104075	
7	Snap Ring	4	9047140	
8	Connection Yoke C	1	74CG1009135	
9	Chain Pin	1	M3041075	
10	Spring Pin	1	9148107	
11	Socket Head Bolt	2	9016105	
12	Washer for #11	6	9012521	
13	Lock Nut	2	9016204	
14	Plain Washer	2	J1WB012-10300	
15	Snap Ring	2	9047130	
16	Pinion	1	T3G121075	
17	Hand Wheel	1	74CG1009222	
18	Slotted Nut	1	J1NL0011012	
19	Plain Washer	1	9012515	
20	Split Pin	1	9009424	
21	Side Plate S Assembly *	1	74CG1005112	
22	Idle Sheave	7	C3BA05010512	
23	Top Idle Sheave Shaft	2	74CG100-91161H	
24	Spring Pin	2	91481110	
25	Suspender C	1	74CG1009134	
26	Suspender A	2	74CG1009201	
27	Suspender B	2	74GC1009202	
28*	Lower Shaft	2	74SH1009563	
29	Thick Spacer	8	72CG1009204	
30	Thin Spacer	32	74SH1009565	
31	Spring Pin	4	91481171	
32	Bottom Idle Sheave Shaft	2	74CG1009207	
33	Spring Pin	4	91481111	
34	Bottom Hook Assembly	1	L42001090	
35	Hook Latch Assembly	1	L41071090	
36*	Upper Shaft	2	74SH1009581	
37	Shaft Stopper Pin	4	MS164075	
38	Split Pin	4	9009435	
39	Thick Spacer	14	MS117075	
40	Fixing Spacer	6	M6SE100S9182	
41	Thin Spacer	22	MS116075	
42	Name Plate - Hook Capacity	1	73CG0759802	73CG1009802
43	Name Plate B – SHB	1	3007174901	
44	Name Plate C – Capsize	1	72CG0109805	

* Not a replacement part. Shown for assembly reference only.

9.2 SHB Parts (8 and 10 Ton)

Figure No.	Part Name	Parts Per Hoist	8 Ton	10 Ton
45	Name Plate C –Trolley Capacity	1	MR2SHM75S9A72	MR2SHM1QS9A72
46	Load Chain	1	LCC3025	
47	Hoist Hand Chain	1	HCCF005	
48	Trolley Hand Chain	1	HCCF005	
49	Stopper Pin	1	M3177025	
50	Split Pin	1	9009414-5	
51	Chain Hoist Body	1	CB025	
52	Chain Stopper Link	1	L4045030	
53	Warning Tag	1	WTAG9	

* **Extended Flange Range Kits:** Kits include 2 Upper Shafts, 2 Lower Shafts, 2 Suspender 'A', Fixing Spacers and Thick Spacers as Required

Model	Flange Range	Kit Part Number
SHB080 & SHB100	8.67" thru 12.0"	7075001

9.2 SHB Parts (8 and 10 Ton Chain Containers - Optional)

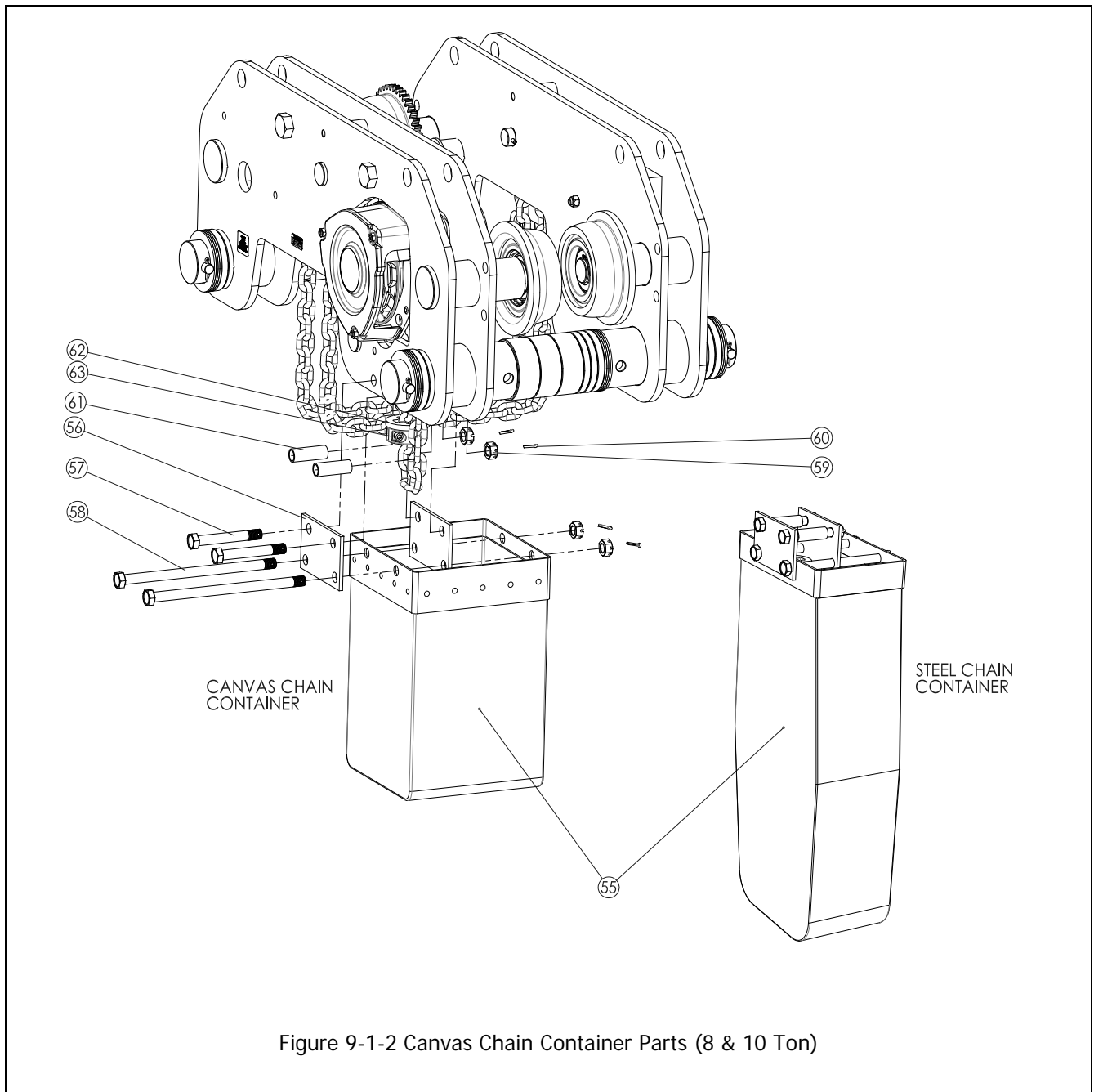

9.2 SHB Parts (8 and 10 Ton Chain Containers – Optional)

Figure No.	Part Name	Parts Per Hoist	8 Ton	10 Ton
54	Canvas Chain Container Assembly (Option)	1	7039809 (13-ft)	
			7039810 (26-ft)	
55	Canvas Chain Container	1	72BD1005101 (13-ft)	
			72BD1005102 (26-ft)	
56	Chain Container Suspender	2	72BD0509301	
57	Container Suspender Bolt A	2	72BD1009201	
58	Container Suspender Bolt B	2	72BD1009202	
59	Slotted Nut	4	J1NL001-10160	
60	Split Pin	4	9009436	
61	Spacer	2	72BD0509203	
62	Stopper Spacer	1	72BD0509401	
63	Stopper	1	ER1ES1041	
54	Steel Chain Container Assembly (Option)	1	7039909 (20-ft)	
			7039910 (30-ft)	
55	Steel Chain Container	1	72BA1005101 (20-ft)	
			72BA1005102 (30-ft)	
56	Chain Container Suspender	2	72BD0509301	
57	Container Suspender Bolt A	2	72BD1009201	
58	Container Suspender Bolt B	2	72BA1009202	
59	Slotted Nut	4	J1NL001-10160	
60	Split Pin	4	9009437	
61	Spacer	2	72BD0509203	
62	Stopper Spacer	1	72BD0509401	
63	Stopper	1	ER1ES1041	

9.2 Drop Stop and Bumper Kits (Optional)

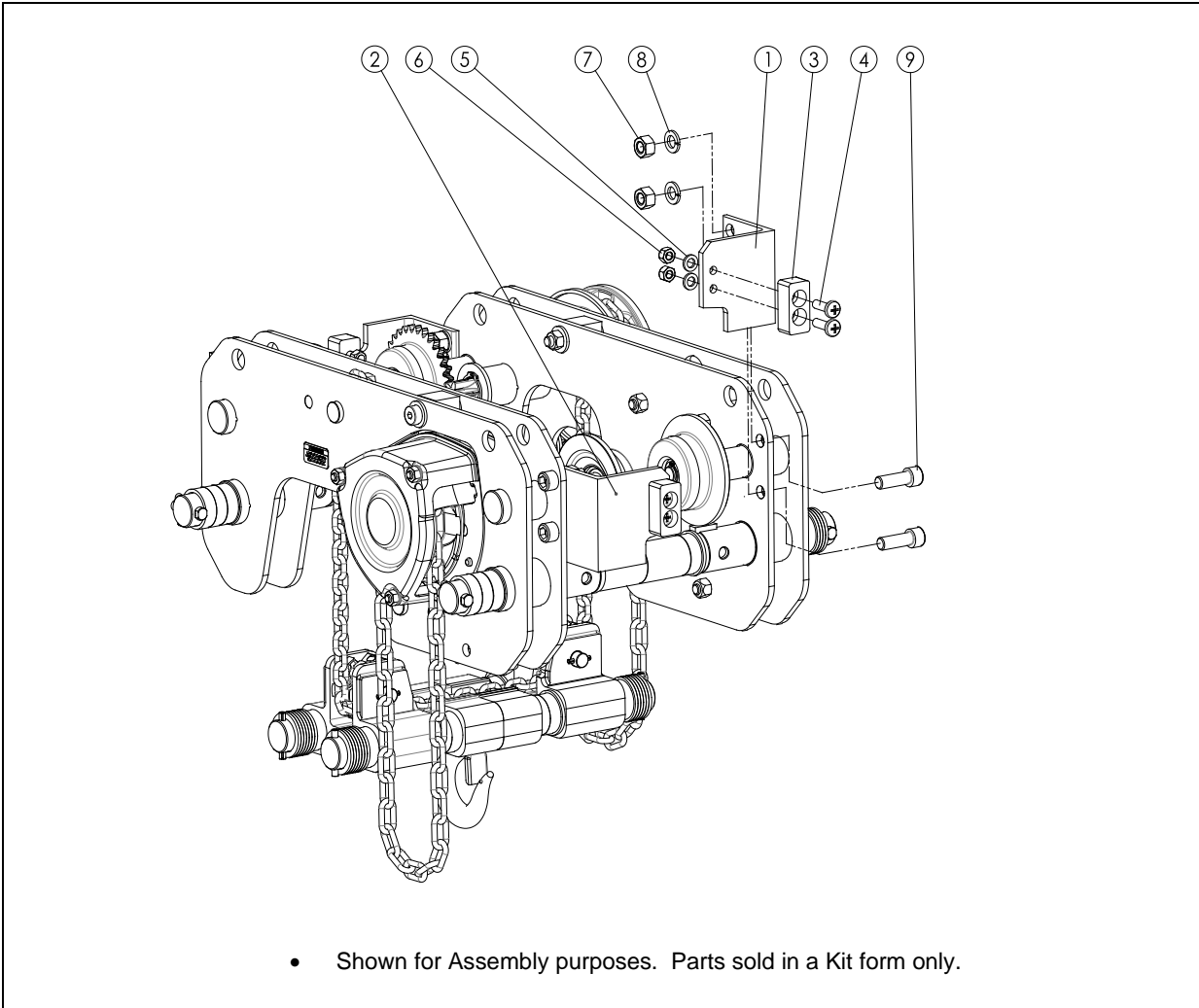

Figure No.	Part Name	Parts Per Hoist	1 Ton Kit	2 Ton Kit	3 Ton Kit	5 Ton Kit	8 & 10 Ton Kit
	Kit Part Number	1	7030501	7030502	7030503	7030504	7030505
1	Drop Stop R	2	7030506	7030508	7030510	7030512	7030514
2	Drop Stop L	2	7030507	7030509	7030511	7030513	7030515
3	Bumper Kit	4	T7AB101010	T7AB101010	T7AB101030	-	-
4	Bumper Bolt	8	-	-	-	-	-
5	Lock Washer	8	-	-	-	-	-
6	Bumper Nut	8	-	-	-	-	-
3	Bumper	4	-	-	-	9004603	9004603
5	Lock Washer	4	-	-	-	9012715	9012715
6	Bumper Nut	4	-	-	-	9003903	9003903
7	Drop Stop Nut	8	9093433	9093433	9093433	9093439	9093439
8	Lock Washer	8	9012713	9012713	9012713	9005315	9005315
9	Drop Stop Bolt	8	90913115	90913117	90913117	90912137	90912137



Harrington Hoists, Inc.
401 West End Avenue
Manheim, PA 17545

www.harringtonhoists.com

Toll Free: 800-233-3010
Phone: 717-665-2000
Fax: 717-665-2861

SHBOM-ENG